



Clear as the air

The indoor air quality is essential to ensuring good quality of life. We have passionately worked for over 45 years with the objective of manufacturing not simply fans, but innovative, technologically advanced, environmentally friendly and human health focused products.



Strong as our prospects

The path followed by our company is part of the history of a large German industrial group, which started as early as 1928, the year when Christian Maier set up Maico Elektroapparate. Since then, the group has been able to build up a well established industrial reality and to acquire the technological and commercial know-how which has allowed it to become one of the top names in the ventilation industry. In the last few years, the group focus to grow on a global level has been speeded up and materialised with important investments in emerging markets: a culturally exciting and highly promising scenario.

Green as the future

Problems like global warming and atmospheric pollution affect us not just as a company working with air but also as human beings. For this reason all our efforts aim to investments, industrial process and products that lead the way in terms of efficiency, cost-effectiveness and environment respect. Many are the rules today that show an ever increasing desire to breathe clean air, from the Kyoto protocol to the many building regulations; we are proud to accept the challenge because we strongly believe that we must work together to win the battle for a clean environment for all. Why not say it, **“it’s our great aspiration!”**



  Dal 1970 la ventilazione made in Italy

For more than 45 years our product range has followed a seamless thread: from the first fans, Elicent policy to combine design, practicality and advanced technology is easy to see. The result is an outstanding Italian product which has earned wide recognition around the world. All our production is 100% made in Italy, in Lonato del Garda (Brescia) where we design and produce all the fans that are then exported in more than 70 countries.



Our products are CE certified and compliant with ErP Directive 2009/125/CE and EU Regulations 327/2011 and 1253/2014.

Guidelines for a correct ventilation

Selecting the correct fan

Extraction is always made from humid/polluted premises: kitchens, laundries, toilets, bathrooms, bars... To choose the fan airflow needed for a specific application, use the following calculation:

$$\text{Airflow} = \text{volume of the room in m}^3 \times \text{number of air changes per hour}$$

Type of room	Air change per hour
Kitchens	6 - 10
Bathrooms and shower rooms	8 - 12
Toilets	8 - 10
Public toilets	10 - 15
Restaurants and bars	10 - 12

Setting the fan correctly

- Fans should always be mounted in the furthest window, wall or ceiling from the main source of air replacement to ensure airflow across the room and avoiding short circuiting of air movement.
- Air replacement should be ensured via internal grilles in the door, ceiling or wall.
- Fans should be located as high as possible in the window or wall nearest to smells or streams but not directly above eye-level grilles or cooker hoods.

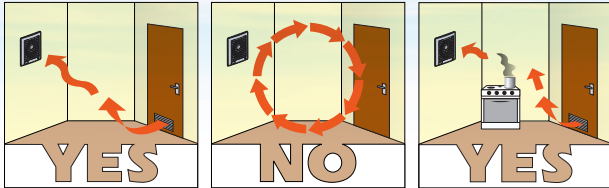

- If installing in a bathroom, the fan must be located where it cannot be touched by a person. Elicent range of 12 Volt SELV fans (Safety Extra Low Voltage) can be installed in zone 1. Fans with IPX4 protection can be installed in zone 2. Fans with an IPX2 protection must be installed in zone 3.

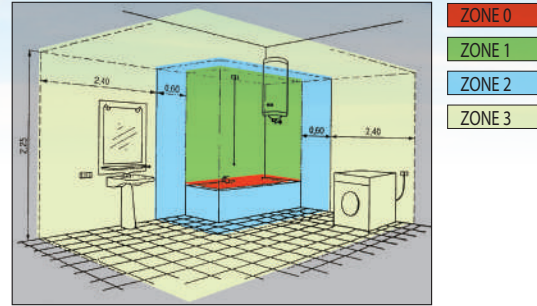

Choosing the right Elicent version

😊 IDEAL SOLUTION

✅ SUITABLE

❌ NOT RECOMMENDED

TYPE OF PREMISE	STANDARD	PULL CORD SWITCH	TIMER/ COMFORTIMER	MHT / COMFORT HYGRO	MHY SMART	PIR	2 SPEED
TOILET	😊	✅	😊	😊	❌	✅	✅
PUBLIC TOILET	✅	✅	✅	✅	❌	😊	😊
BATHROOM	✅	✅	✅	😊	😊	❌	✅
SHOWER ROOM	✅	✅	✅	✅	😊	❌	✅
KITCHEN	😊	😊	✅	✅	✅	❌	✅
LAUNDRY	✅	✅	✅	😊	✅	❌	😊
OFFICE	✅	✅	✅	❌	❌	❌	😊

Operation

STANDARD version
Light/remote control switch.

PULL CORD switch

TIMER
Integral electronic timer adjustable from 3 to 25 minutes.

COMFORTIMER
Microchip Timer version adjustable from 3 to 25 mn with overrunning at low speed for an energy saving up to 64% compared to a standard timer version. The low speed guarantees increased silence and energy saving though maintaining a fully satisfying exhausting efficiency. Version particularly suitable for hotels, hospitals, private homes and for all those applications where silence is a must.

MHT humidity control
Integral humidity control adjustable from 40 to 80% of R.H.

MHY Smart humidity control
Provided with the latest microchip technology. Operation: automatic and progressive increase / decrease of the motor speed according to the percentage of R.H.

COMFORT HYGRO
Combines to Comfortimer technology a microchip humidity sensor adjustable from 40 to 80% of R.H.

P.I.R.
Passive infra-red sensor with integral adjustable timer from 3 to 25 minutes.

12 VOLT
Low voltage version.

2 V
Double speed version (24 hours running at the lowest speed).

EC MOTOR
High efficiency, electronically controlled, brushless motor.

Product Specification

INSTALLATION

Direct exhaust to the outside

Ducted installation

CERTIFICATIONS

IMQ approved

Product compliance with EC Directive

PROTECTION

Double insulation - Class II earth connection not required

International Protection rating

Splash proof protection (EN 60335-2-80)

Drop protection (EN 60335-2-80)

Maximum operating temperature

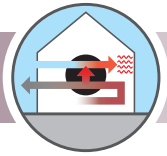

VENTILATION WITH HEAT RECOVERY

Decentralized HRU		pag.
	REC Smart - Single Room HRU	8
	REC Smart PLUS - Single Room HRU	10
	REC Duo 100 - Single Room HRU	12
	REC San Air - Single Room HRU	14
Centralized HRU		pag.
	REC in linea - HRU horizontal installation	18
	REC 280 - 320 - HRU vertical installation	22

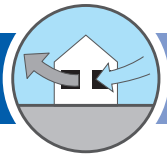

EXTRACT VENTILATION

Centralized extract ventilation		pag.
	MICROBOX	26
	MULTIBOX	27
	AXM	28
	EXT	30
	MRF	31
	AXC	32
	AXC TP	33

Decentralized extract ventilation		pag.
AXIAL FANS		
	E-MAX	35
	E-SMILE	36
	ELEGANCE	37
	E-STYLE <i>PRO</i>	40
	E-STYLE <i>TREND</i>	41
	E-STYLE <i>PIR</i>	42
	ECOLINE	43
	MINISTYLE	45
	MURO	46
	JOLLY	47
	TUBO	48
	BUILT-IN	49
	ECOWIND	50
	VITRO	51
	MINIVITRO	53



CENTRIFUGAL FANS		
	ELIX	54
	ELPREX	57
	FLUX	59
	RADIA	60
	TIRAFUMO	61

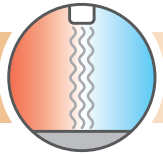

EC versions



AIR CURTAINS

		pag.
	ELDOOR CZ	63
	ELDOORTZ	63





HEATING

		pag.
	CALDO 500	65
	CALDO BAGNO 2000	65
	CALDO LAMP 1500	66
	CALDO LAMP 1500 GOLD	66
	CALDO TURBO 2000 TECH	67
	CALDO TURBO / CALDO 2000	67
	VOLCANO R	68
	VOLCANO PRO	68







VENTILATION

		pag.
	MP800 - Air scatters	70
	POLAR EVOLUTION - Reversible ceiling fans	70



HYGIENE

		pag.
	ECOJET - Ecological and high speed hand-dryer	73
	ECOFLOW - Ecological antivandal hand-dryer	74
	HD 300 - Antivandal hand-dryer	75
	HD 100 - Classic hand-dryer	76
	HR 100 - Hair dryer	77

SENSORS & CONTROLLERS

78

ACCESSORIES

82

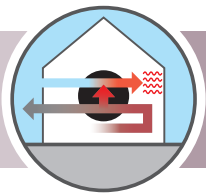

RESIDENTIAL VENTILATION WITH HEAT RECOVERY

Ventilation with heat recovery is a clean and simple technology which provides great comfort and savings: it enables to create an hygienic microclimate throughout the home, combining comfortable living, protection of the building and energy efficiency.



SAVINGS

- Lower heating and air conditioning bills.

- Low energy consumption.

Optimising insulation investments (window frames, wall and loft insulation, roof) which would be wiped out with a natural ventilating system: on average, in fact, open windows lead to a loss of 50% of heat from the home.



WELLBEING

- Fresh, clean air at a comfortable temperature improves your quality of life and sleep.

- A clean and filtered air prevents allergens from multiplying and promotes the removal of pollutants.

- Low noise level: quiet equipment operation and protection from external noises.



PROTECTING YOUR PROPERTY

- Preventing damage caused by dampness and condensation.

- Preventing mould.

- Protecting the value of your property.



COMFORT

- Practical, versatile and customisable modular operation.

- A reliable system which ensures the correct ventilation in every season.

- The ideal solution for energy requalification of buildings.

INTEGRATED SOLUTIONS FOR A WHOLE-HOUSE COMFORT

Decentralized HRU

Suitable for any kind of room.



RECsmart



RECsmart+



RECduo100

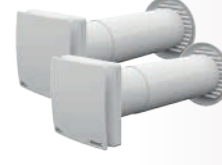

RECSanAir



Centralized HRU

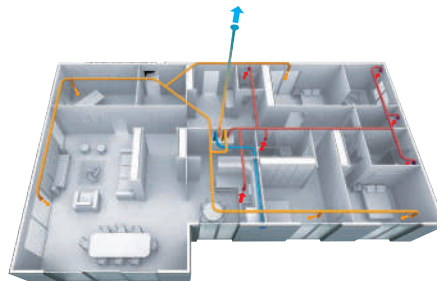

The centralized HRU is located in a technical room or in a false ceiling. The hot internal air extracted from the premises goes through a heat exchanger before being expelled outside. The fresh air coming from outside is first filtered and then goes through the exchanger where it recuperates the heat released by the extracted air.

RECin linea
Horizontal Installation



REC 280 320
Vertical Installation

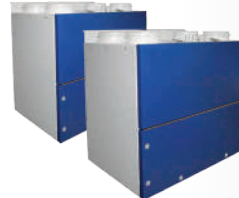

Touch Panel

Decentralized HRU



5 Good reasons to choose it

- Need to better the indoor air quality with punctual solutions for each kind of room.
- Presence of an air quality or ventilation problem limited to a unique room or a small house.
- Impossibility to install a centralized HR system.
- Need to renovate or requalify the house at limited costs.
- Avoid important masonry interventions.

REC^{smart}

STANDARD version

HUMIDITY CONTROL version

REC^{smart+}

Version with REMOTE CONTROL

Version with TOUCH CONTROL

Ø100 mm

Single room HRU

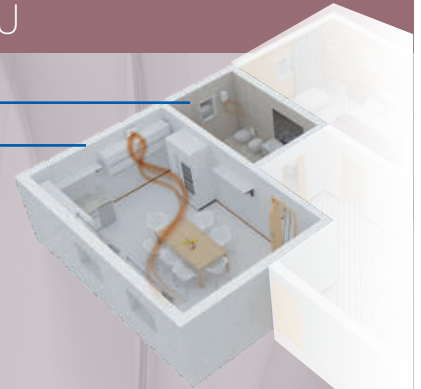

REC^{duo}₁₀₀

STANDARD / 2V version

REC DUO 100 MHY Humidity control version

REC DUO 100 PLUS RC Full optional version with remote controll

NEW

Ø100 mm
Wireless communication

HRU for installation in single or separate rooms



REC^{SanAir}

REC SanAir WALL

REC SanAir IN WALL

REC SanAir WINDOW

Single - Room HRU





For single rooms up to 40 m²



Comply with ErP Directive and UE Regulation 1253/2014 Ventilation Unit (VU)

- Thermal efficiency up to **75%**
- Easy to install: no ducting system or heavy masonry required. A hole of \varnothing 100 mm is sufficient.
- Ideal for refurbishment and energy requalification.
- Drastic solution to humidity and condensate problems.
- EC motors.

OPERATION

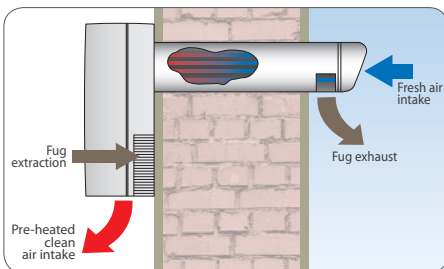

- Tubular heat exchanger with separate flows for a perfect hygiene.
- Balanced double flow, 24/7 running.

ACCESSORIES



Built-in installation

RLS Remote Speed control (min-max) and on/off switch.

- New design with cover
- Suitable for surface or built-in installation
- Ease of connection by the means of removable terminals
- Protection IP42
- Weight 0,40 Kg
- Supply voltage 230V – 50/60 Hz
- Dimensions 110 x 80 x 42

FEATURES

- 3 models with duct \varnothing 100 mm and 3 standard lengths for wall thickness up to 600 mm.
- Suitable for any kind of room. Ideal for wet rooms like kitchens and bathrooms.
- Extremely compact and versatile: can be installed in horizontal or vertical position.
- High energy saving thanks to EC motors
- Integrate by-pass and antifreeze functions.
- Provided with 3 filters: the air is filtered in both flows before entering the heat exchanger.
- Easy maintenance and cleaning: filters and heat exchanger are removable and washable.
- Comply with EN 60335-2-80, B.T. 2014/35/UE, EMC 2014/30/UE.

PERFORMANCE

MODELS	DUCT		WALL THICKNESS		V	m ³ /h	l/s	W	A	dB(A)		Kg
	\varnothing mm	max mm	LwA	LpA*								
STANDARD Version												
REC Smart 100/400	100	400	230	27 / 53	8 / 15	8,3 / 28,3	0,075 / 0,207	48,3 / 59,4	27,7 / 39,3	3,8		
REC Smart 100/500	100	500	230	27 / 53	8 / 15	8,3 / 28,3	0,075 / 0,207	48,3 / 59,4	27,7 / 39,3	3,9		
REC Smart 100/600	100	600	230	27 / 53	8 / 15	8,3 / 28,3	0,075 / 0,207	48,3 / 59,4	27,7 / 39,3	4,0		
MHY Version												
REC Smart 100/400 - MHY	100	400	230	27 / 53	8 / 15	8,3 / 28,3	0,075 / 0,207	48,3 / 59,4	27,7 / 39,3	3,8		
REC Smart 100/500 - MHY	100	500	230	27 / 53	8 / 15	8,3 / 28,3	0,075 / 0,207	48,3 / 59,4	27,7 / 39,3	3,9		
REC Smart 100/600 - MHY	100	600	230	27 / 53	8 / 15	8,3 / 28,3	0,075 / 0,207	48,3 / 59,4	27,7 / 39,3	4,0		

* Lp(A) measured at 3m in open field 230V-50Hz.



F7 filter Upon request

INSTALLATION EXAMPLES



Suitable for any kind of room
Ideal for wet rooms like kitchens and bathrooms.

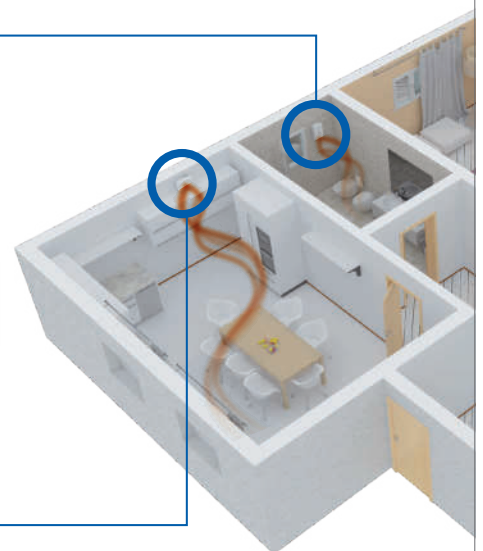

VERSIONS

STANDARD
version



I 24/7 running at the minimum speed.



II The unit switches at the highest speed through a manual command on a remote control (switch, push button or RLS controller).

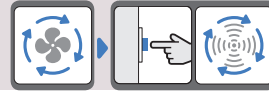

III The highest speed is provided with a timer (adjustable from 0 to 30 minutes). At the end of the delay running, the fans automatically turns back to the minimum speed.



MHY Version

Humidity control



I 24/7 running at the minimum speed.



II The unit switches to the highest speed automatically through the humidity sensor. The maximum speed is reached progressively according to the humidity level of the room.

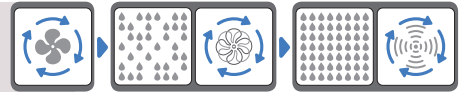

III Once the humidity goes under the pre-set level (adjustable from 40 to 90% of R.H.), the unit automatically switches to the minimum speed.

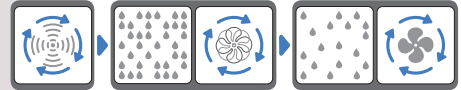

Also the MHY version is provided with a timer adjustable from 0 to 30 minutes for the manual boost at the maximum speed. The function is useful in case it is necessary to have the fan running at the maximum speed independently from the humidity level (see point III standard version).



DIMENSIONS (mm)

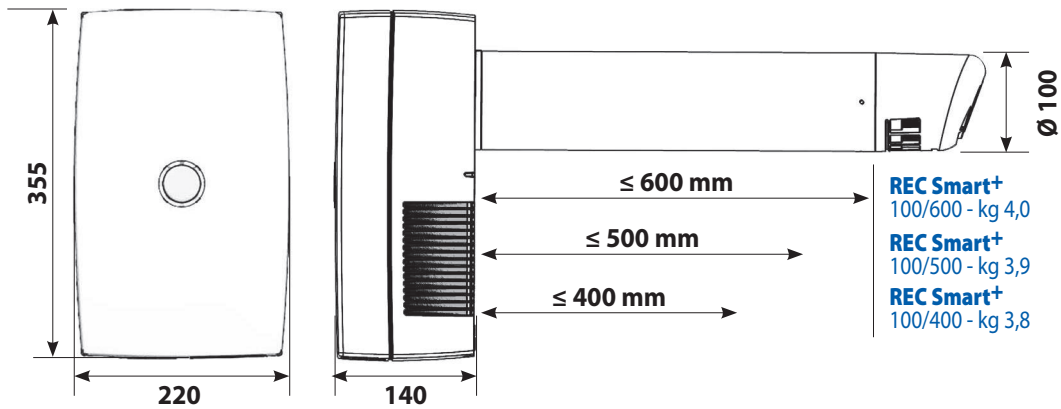

INSTALLATION

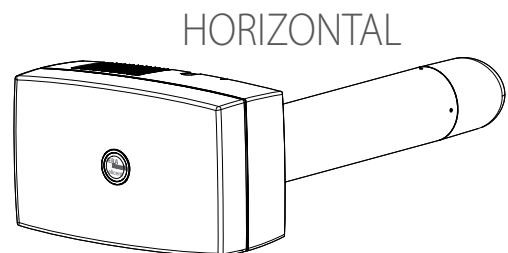
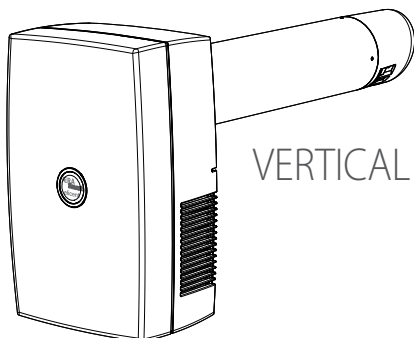



Single rooms up to 40 m²



Comply with ErP Directive 2009/125/CE and EU Regulation 1253/2014. Residential Ventilation Unit.

- Integrated Humidity Control
- Thermal efficiency up to **75%**
- Easy to install: no ducting system or heavy masonry required. A hole of \varnothing 100 mm is sufficient.
- Ideal for refurbishment and energy requalification.
- Drastic solution to humidity and condensate problems.
- EC motors.

OPERATION

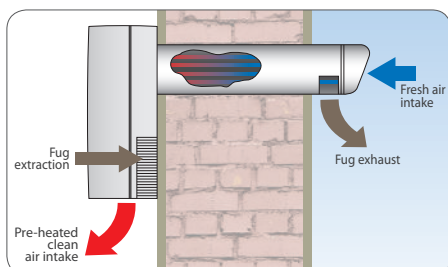

- Tubular heat exchanger with separate flows for a perfect hygiene.
- Balanced double flow, 24/7 running.

FEATURES

- **REC smart+** is available in a range of 3 models corresponding to 3 different duct length, with a unique duct diameter 100 mm. The measures reported on the dimensional drawing refer to the maximum thickness of the wall on which the ventilation unit can be installed: 400, 500, 600 mm.
- 3 models with duct \varnothing 100 mm and 3 standard lengths for wall thickness up to 600 mm.
- Suitable for any kind of room. Ideal for wet rooms like kitchens and bathrooms.
- Extremely compact and versatile: can be installed in horizontal or vertical position.
- High energy saving thanks to EC motors
- Integrate by-pass and antifreeze functions.
- Provided with 3 filters: the air is filtered in both flows before entering the heat exchanger.
- Easy maintenance and cleaning: filters and heat exchanger are removable and washable.
- Comply with EN 60335-2-80, B.T. 2006/95/CE, EMC 2004/108/CE.

OPERATION

REC smart+ is designed for a 24 hours running at the minimum speed. The unit switches at the highest speed through a manual command on a remote controller (remote switch / push button, radio controller or Touch Panel) or automatically (through the integrated humidity sensor or via the Touch Panel weekly programming). Both models RC and TC are provided with the MHY Smart humidity control (a technology patented by Maico Italia) which allows to have the ventilation speed automatically set according to the detected humidity level.

The BOOST function (maximum speed) is provided with a timer (adjustable from 0 to 30 minutes) that can be activated through remote controller (switch, light switch, radio controller, touch panel). The function is useful in case it is necessary to have the unit running at the maximum speed independently from the humidity level.

MODELS



REC smart+ RC

The model is supplied with a remote radio controller. The ventilation unit is provided with 3 LED that indicate the operation modality, including the sleep mode and the extraction mode, as well as the indication of potential anomalies.

Through the remote radio controller it is possible to manage the following functions:

- On/Off
- The Speed/ventilation level regulation
- The Sleep modality that allow to have the unit running silently at low speed during the night (the boost function is excluded)
- The post-ventilation function (Timer function, adjustable from 0 to 30 minutes) to delay the switching of the unit at the minimum speed



REC smart+ TC

The model is supplied with a remote Panel Touch controller with coloured screen. The ventilation unit is provided with 3 LED that indicate the operation modality, including the sleep mode and the extraction mode, as well as the indication of potential anomalies.

The Touch Panel allows to manually or automatically manage (through the weekly programming) the following functions:

- The Speed/ventilation level regulation
- The ventilation modality (by-pass function, free-cooling, only extraction, only immission)
- The threshold humidity level over which the unit increases its speed
- The post-ventilation function (Timer function, adjustable from 0 to 30 minutes) to delay the switching of the unit at the minimum speed)
- The Sleep modality that allow to have the unit running silently at low speed during the night (the boost function is excluded)

PERFORMANCE

MODELS	DUCT Ø mm	WALL THICKNESS max mm	V	m³/h	l/s	W	A	dB(A)		Kg
								LwA	LpA*	
RC RECsmart+ RADIO CONTROL										
REC Smart+ L400 + REMOTE CONTROLLER	100	400	230	27 / 53	8 / 15	8,3 / 28,3	0,075 / 0,207	48,3 / 59,4	27,7 / 39,3	3,8
REC Smart+ L500 + REMOTE CONTROLLER	100	500	230	27 / 53	8 / 15	8,3 / 28,3	0,075 / 0,207	48,3 / 59,4	27,7 / 39,3	3,9
REC Smart+ L600 + REMOTE CONTROLLER	100	600	230	27 / 53	8 / 15	8,3 / 28,3	0,075 / 0,207	48,3 / 59,4	27,7 / 39,3	4,0
TC RECsmart+ TOUCH CONTROL										
REC Smart+ L400 + TOUCH PANEL	100	400	230	27 / 53	8 / 15	8,3 / 28,3	0,075 / 0,207	48,3 / 59,4	27,7 / 39,3	3,8
REC Smart+ L500 + TOUCH PANEL	100	500	230	27 / 53	8 / 15	8,3 / 28,3	0,075 / 0,207	48,3 / 59,4	27,7 / 39,3	3,9
REC Smart+ L600 + TOUCH PANEL	100	600	230	27 / 53	8 / 15	8,3 / 28,3	0,075 / 0,207	48,3 / 59,4	27,7 / 39,3	4,0

* at 3 m in open field

INSTALLATION

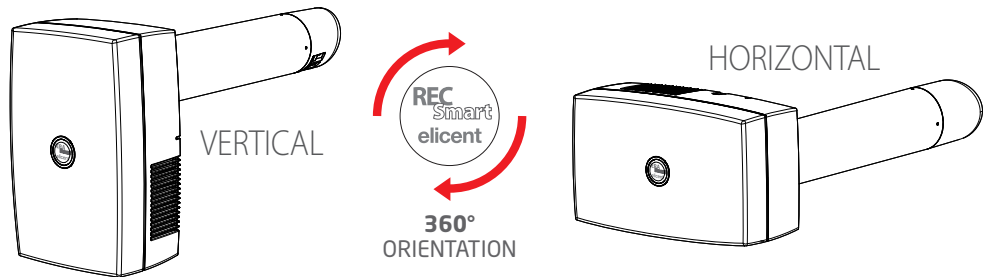

DIMENSIONS (mm)

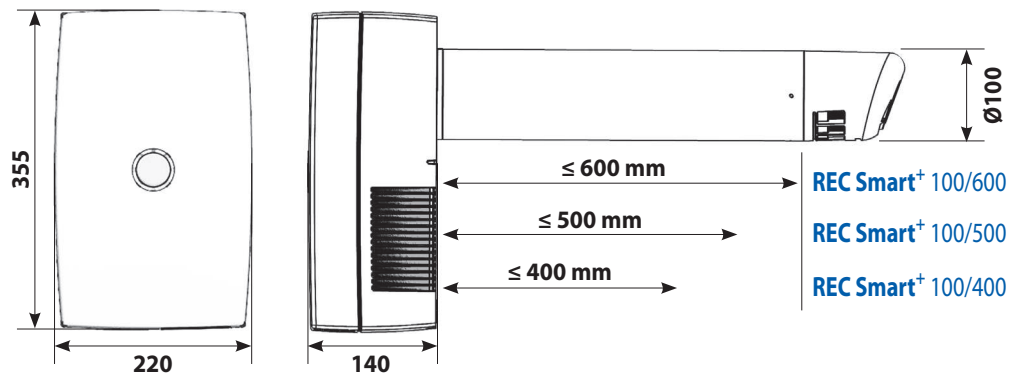

REMOVE THE MOULD AND BREATHE A HEALTHIEST AIR !



BEFORE

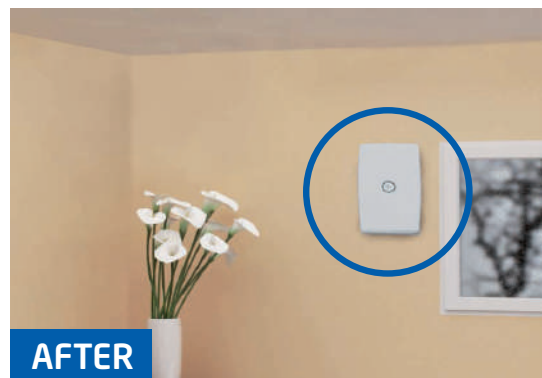

AFTER



REC duo 100

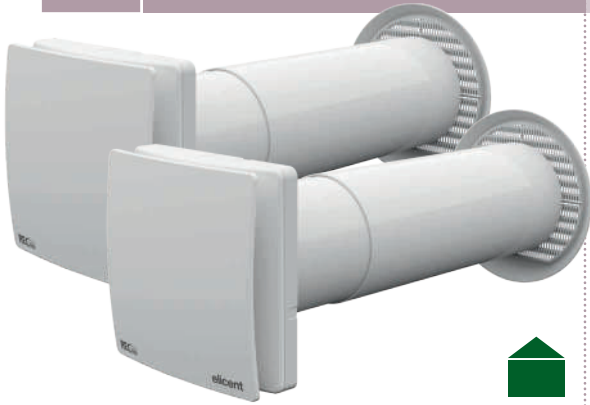

**Coupled installation
in a single room
or 2 separate rooms**



Comply with ErP Directive 2009/125/CE and EU Regulation 1253/2014. Residential Ventilation Unit.

- Thermal efficiency up to **90%**
- Ø100
- Easy Installation and maintenance:
 - Magnetic coupling/uncoupling of the unit.
 - External grille with net, installable from the inside.
 - Telescopic duct.
- Wireless communication (REC duo 100 PLUS RC)

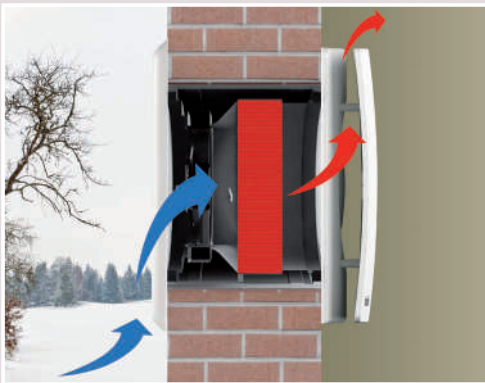

REC Duo 100 is a "push-pull" HRU with reverse flow. It is provided with a ceramic heat exchanger that accumulates the heat from the extracted air during the "pull" cycle and releases it to the new fresh air during the "push" cycle.

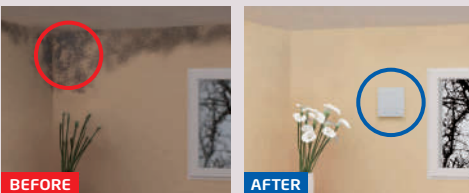
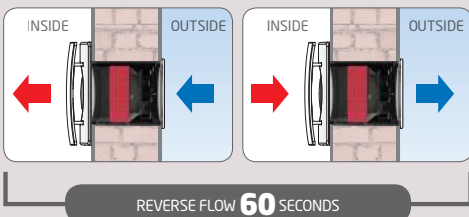

Decentralized Heat Recovery Unit

FEATURES

- Very high efficiency decentralized HRU with heat recovery up to 90%.
- Ideal for residential applications and in any ambient where it is necessary to ensure a constant thermal comfort both in the summer and in the winter.
- Suitable for any kind of rooms.
- A coupled installation is recommended to optimize the system efficiency, in a single room or separate rooms.
- Direct exhaust through walls with thickness from 300 to 500 mm (adaptable to other wall thickness from 220 to 1000 mm: see section Dimensions).
- Suitable for conveying air to a max. temperature of 40°C.
- Stylish and ultra-slim front cover. Very compact dimensions.
- Provided with filters G3 class both in intake and in extract, easily removable and washable.
- Free-cooling function.
- EC brushless motor.
- Comply with EN 60335-2-80, LVD 2014/35/UE, EMC 2014/30/UE.
- IPX4
- CE marked

EXAMPLES OF INSTALLATION

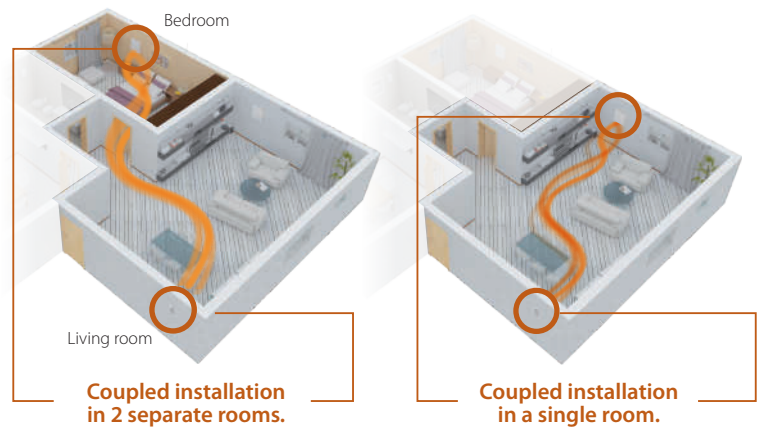

PERFORMANCE

MODEL	DUCT	WALL THICKNESS	AIR FLOW min / max only exhaust	V AT 50 HZ.	W min / max only exhaust	dB(A)
	Ø (mm)	min. / max (mm)	m³/h			Lp
REC Duo 100 - 100 MHY - 100 Plus RC	107	300 - 500	12 / 30 / 40	230	1 / 2,8 / 3,5	15 / 29

* at 3 m in open field

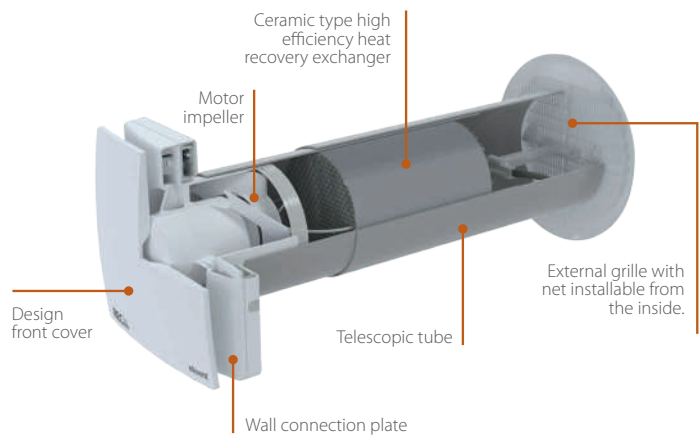

MAGNETIC COUPLING UNCOUPLING OF THE UNIT TO THE CONNECTION PLATE



MODELS & OPERATION



REC DUO 100
Cod. 2RC1100

24 hours running in push-pull modality at low speed (selectable between 2 at installation).
The unit switches to the extraction operation modality when speed boost is activated through remote control switch or RLS controller (available as accessory). The maximum speed is provided with a timer (adjustable from 0 to 30 minutes). Once concluded the overrun via timer, the fan automatically switches back to the push-pull operation modality at low speed.



REC DUO 100 MHY
Cod. 2RC1200

24 hours running in push-pull modality at low speed (selectable between 2 at installation).
The unit switches to the extraction operation modality when speed boost is activated, manually or automatically: **Manually** via control switch or RLS controller (available as accessory). The maximum speed is provided with a timer (adjustable from 0 to 30 minutes). Once concluded the overrun via timer, the fan automatically switches back to the push-pull operation modality at low speed.
Automatically via humidistat (adjustable from 45 to 85% of R.H). The fan speed increases/decreases according to the humidity level detected above the pre-selected threshold. It then switches back to the push-pull operation modality at low speed when the humidity level goes beneath the pre-selected threshold.

RLS
Cod. 2RV4158

Available as accessory for REC DUO 100 and REC DUO 100 MHY



- On-Off
- Boost speed



REC DUO 100 PLUS RC
Cod. 2RC1300

24 hours running in push-pull modality at low speed (adjustable by the end-user).
Boost speed is available in push-pull modality and turns on automatically via humidistat (adjustable from 45 to 85% of R.H) and increases/decreases progressively according to the detected humidity level.
In case of a persistent and high concentration of humidity, the unit automatically switches to the extraction operation modality. It then switches back to the push-pull operation modality at low speed when the humidity level goes beneath the pre-selected threshold. The unit is supplied with a remote controller for the selection and activation of advanced comfort ventilation functions.

REC Duo 100 PLUS RC is supplied with a remote controller through which selecting the speed and managing the following operation modalities:

0 - On/off

1 - Push-pull operation modality

24 hours reverse flow running at the selected speed

2 - Speed 1

3 - Speed 2

4 - Boost speed with timer (extraction mode only)

5 - Sleep mode

the operation at low speed is frozen for 8 hours to ensure high acoustic comfort during the night. The function can be unblocked at any time by pressing any button (except button 0).

6 - Flow control

operation in intake or extract mode only.
Press once: extraction mode
Press twice: intake mode

7 - Free-cooling mode: air exchange without heat recovery

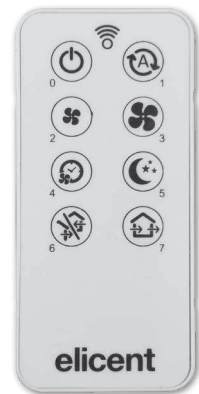

Led signal:
any time a button is pressed, a led switches on the remote controller to indicate that the signal has been received.

DIMENSIONS (mm)

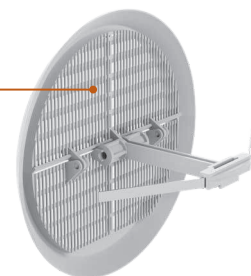
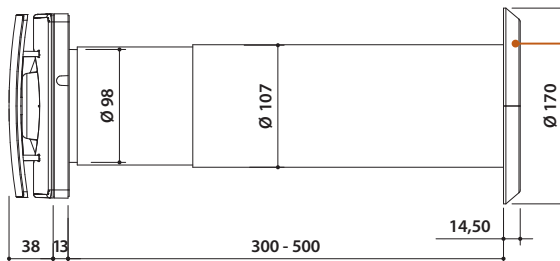
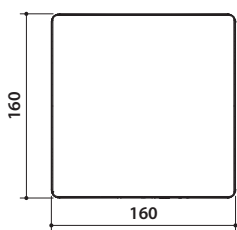

External grille installable from the inside.



For walls with thickness > 500 mm:

It is necessary to use the telescopic duct available as accessory
Cod. 2KT0014

For wall thickness between 220 and 300 mm:

It is necessary to cut the duct and to use the external grille MFE, available as accessory
Cod. 2GE2002



REC SanAir WALL



REC SanAir IN WALL



REC SanAir WINDOW



Single rooms up to 40 m²



Comply with ErP Directive 2009/125/CE and EU Regulation 1253/2014
Classification: Residential Ventilation Unit.

- Thermal efficiency up to 82%
- Highly efficient filtering system
- Enthalpic heat exchanger
- EC motors

FEATURES

- Decentralised heat recovery unit with high efficiency enthalpic heat exchanger for residential application.
- Thermal efficiency up to 82%.
- Very high efficiency filtering system with double filter F8 + G4 **which allows the retention** of at least 98% of PM2,5, 99% of PM10 and 100% of pollens.
- Ultra slim and aesthetic design. Lightweight and easy to install.
- Wall/window frame installation
- 5 ventilation levels: from 15 to 41 m³/h.
- Free-cooling and Antifreeze functions.
- Low consumption: from 4 W
- Silent running: < 30dB in night mode.
- Comply with B.T. 2014/35/UE, EMC 2014/30/UE.
- **CE** marked

PERFORMANCE

SPEED	AIRFLOW	ELECTRIC POWER	SOUND PRESSURE	THERMAL EFFICIENCY
	m ³ /h	W	dB (A)	%
1	15	4	26	82
2	20	5	30	-
3	30	10	36	74
4	35	13	40	-
5	41	20	44	69

TECHNICAL DATA

Heat recovery depending in T, RH, AIRFLOW	up to 82%
Rated input voltage	220 V a.c.
Internal operating voltage	24V c.c.
Power supply	230V / 50 Hz
Safety class	II
Safety	Transformer provided with thermal protection
Protection grade	IP65
Connection cable length	2,5 mt
Temperature range	Min. -15°C / Max 50°C
Thermal transmission coefficient	U= 0,30 W/K
Noise attenuation	oltre 43 dB
Provided filters	F8/F9 + G4 - immission G4 - extract

REMOTE CONTROL



REC San Air is supplied with a remote control for the set-up of the ventilation level and the free cooling function (with programmable timer up to 10 hours).



MODELS

REC SanAir WALL

- Installation on all kind of perimetric wall.
- Unique model for horizontal or vertical installation.
- Easy installation: 2 holes of ø100 mm are sufficient.

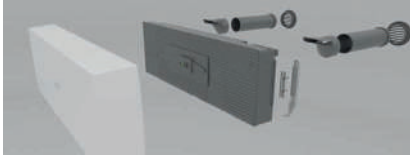



ITEM	CODE	DESCRIPTION
REC SANAIR WALL - Wall installation - Horizontal or vertical installation		
	4SA0000	REC SanAir WALL

REC SanAir IN WALL

- Installation on any kind of perimetrical wall.
- Built-in horizontal or vertical installation.



ITEM	CODE	DESCRIPTION
REC SANAIR WALL - Built-in horizontal installation		
	4SA0001	REC SanAir WALL IN
	5SC5000	Built-in frame with rear
	5KT0009	External direct extensions
	5KT0010	External extensions 45° curved
	5FR5000	REC San Air white cover RAL 9010

ITEM	CODE	DESCRIPTION
REC SANAIR IN WALL - Built-in vertical installation		
	4SA0001	REC SanAir WALL IN
	5SC5001	Built-in frame with rear + 90° curved
	5KT0009	External direct extensions
	5FR5000	REC San Air white cover RAL 9010

REC SanAir WINDOW



- Installation on all kind of window frame with dimensions up to 180 mm of width and 3000 mm of length.

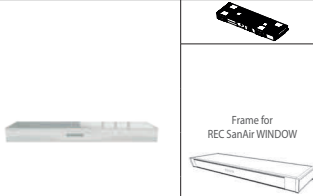

ITEM	CODE	DESCRIPTION
REC SAN AIR WINDOW - Window installation		
	4SA0002	REC SanAir WINDOW
	5SC5010	L. 1.000 White RAL 9010
	5SC5011	L. 1.500 White RAL 9010
	5SC5012	L. 2.000 White RAL 9010
	5SC5013	L. 2.500 White RAL 9010
	5SC5014	L. 3.000 White RAL 9010

ACCESSORIES / SPARE PARTS

ACCESSORIES / SPARE PARTS

	5KT0011	Direct extension kit
	5SL0050	Remote control
	5KT0012	Filter G4 + F8

DIMENSIONS (mm)

WALL model

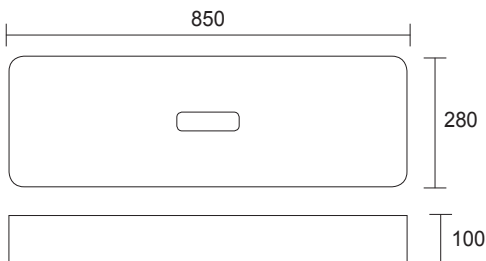

WINDOW model



Frame	X (mm)
5SC5010	1000
5SC5011	1500
5SC5012	2000
5SC5013	2500
5SC5014	3000

For intermediate quotes it is possible to shorten the extension and the grill on site.

IN WALL model

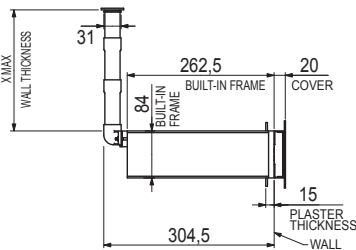
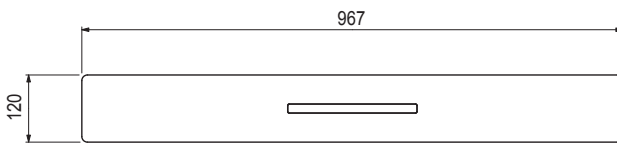

Vertical configuration

Wall thickness quote X (mm)	Extensions and external grill needed		CODE Extensions Kit
	External grill	Extensions	
61	1+1	NO	5KT0009
136	1+1	1+1	5KT0009
211	1+1	2+2	5KT0009
286	1+1	3+3	5KT0009 + 5KT0011

For intermediate quotes it is possible to shorten the extension and the grill on site.

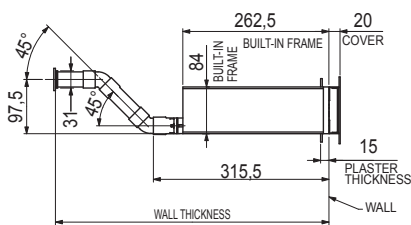

Horizontal configuration with extension 45°

Wall thickness quote X (mm)	Extensions and external grill needed		CODE Extensions Kit
	External grill	Extensions	
491	1+1	NO	5KT0010
566	1+1	1+1	5KT0010
641	1+1	2+2	5KT0010 + 5KT0011
716	1+1	3+3	5KT0010 + 5KT0011
791	1+1	4+4	5KT0010 + 5KT0011
866	1+1	5+5	5KT0010 + 5KT0011

For intermediate quotes it is possible to shorten the extension and the grill on site.

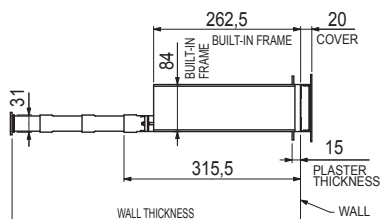

Horizontal configuration with direct extension

Wall thickness quote X (mm)	Extensions and external grill needed		CODE Extensions Kit
	External grill	Extensions	
365	1+1	NO	5KT0009
440	1+1	1+1	5KT0009
515	1+1	2+2	5KT0009
590	1+1	3+3	5KT0009 + 5KT0011
665	1+1	4+4	5KT0009 + 5KT0011
740	1+1	5+5	5KT0009 + 5KT0011
815	1+1	6+6	5KT0009 + 5KT0011

For intermediate quotes it is possible to shorten the extension and the grill on site.

Centralized HRU

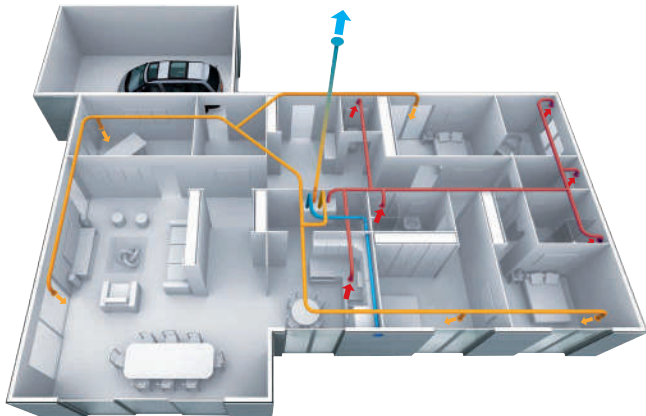

The centralized HRU is located in a technical room or in a false ceiling. The hot internal air extracted from the premises goes through a heat exchanger before being expelled outside. The fresh air coming from outside is first filtered and then goes through the exchanger where it recuperates the heat released by the extracted air.



Residential ventilation units - Horizontal installation

2 - 8 rooms



REC in linea 140

Thermal efficiency **91%**
EC Brushless Motor
 Free cooling / Integrated By-pass
 Energy Class **A**

- Ideal up to 4 rooms
- Airflow up to **140 m³/h**
- Low consumption (**min. 10W**)



REC in linea 180

Thermal efficiency **91%**
AC or EC Brushless Motors
 Free cooling / Integrated By-pass
 Energy Class **A (EC)**

- Ideal up to 6 rooms
- Airflow up to **180 m³/h**
- Low consumption (**min. 15W EC - min. 60W AC**)



REC in linea 220



Thermal efficiency **91%**
AC or EC Brushless Motors
 Free cooling / Integrated By-pass
 Energy Class **A (EC)**

- Ideal up to 8 rooms
- Airflow up to **220 m³/h**
- Low consumption (**min. 35W EC - min. 60W AC**)

Residential ventilation units - Vertical installation

up to 10 rooms



REC 280



Thermal efficiency **93%**
AC motor
 Free cooling / Integrated By-pass

- Ideal up to **10 rooms**
- Airflow up to **280 m³/h**
- Low consumption (**min. 80W**)



REC 320



Thermal efficiency **93%**
EC brushless motor
 Free cooling / Integrated By-pass
 Energy class **A**

- Ideal up to **10 rooms**
- Airflow up to **320 m³/h**
- Low consumption (**min. 40W**)
- **Available with Touch Panel included (TC version)**



New versions with **Touch Panel** for the weekly programming of the indoor comfort.

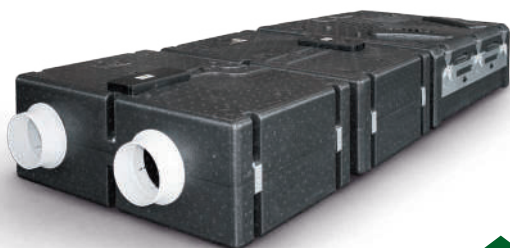

2 - 8 rooms

Energy class A (EC Versions)



Comply with ErP Directive and UE Regulation 1253/2014 Ventilation Unit (VU)

- Thermal efficiency up to **91%**
- High energy saving thanks to EC motors
- Compact and modular
- Energy Class A (EC versions)

VERSIONS

REC in linea AC

Provided with external rotor motor and forward blade impeller 2 speed running: continuous running at the minimum speed, maximum speed is activated through remote control.

REC in linea EC

Provided with brushless motor for an optimal combination between high performance, silence and low energy consumption.

CONTROLLERS

SUPPLIED

RLS 1 WR

- Remote control
- Manual selection of three modality of continuous running:
 - I - Low ventilation modality
 - II - Intermediate ventilation modality
 - III - Intensive ventilation modality
- Supply voltage 230V - 50/60 Hz
- Weight 0,50 Kg
- Dimensions 75 x 75 x 30



Supplied with REC in linea EC 140 - 180 - 220

ACCESSORY

RLS 3V - 3 speeds

- Remote 3 speed control (Min/Max) and On/Off switch
- New design with cover
- Suitable for surface or built-in installation
- Ease of connection by the means of removable terminals
- Protection IP42
- Weight 0,40 Kg
- Supply voltage 230V - 50/60 Hz
- Dimensions 110 x 80 x 42



Accessory for AC versions of REC in linea 180

FEATURES

- High efficiency centralized heat recovery units with thermal efficiency up to 91%.
- Compact and modular.
- Horizontal installation in false ceilings.
- Lightweight and easy to install.
- Suitable for \varnothing 125 mm ducting system.
- Made in PPE for a perfect thermal and acoustic insulation.
- Provided with integrated by-pass.
- Multispeed high efficiency EC brushless motors.
- Low sound level.
- Filters class M6 in addition to the filters assembled.
- Supplied with fixing plate, and RLS 1WR control panel (EC motor versions).
- IPX2.
- Comply with EN 60335-2-80, B.T. 2014/35/UE, EMC 2014/30/UE
- Performance measured by BRE according to EN 13141-7, EN 13101-4, EN 5801 and EN 308.
- CE marked

PERFORMANCE

MODEL	m ³ /h max	l/s	Pa max	V	W max	A max	dB(A)*
REC in linea 140 EC	140	39	210	230	50	0,55	24
REC in linea 180 EC	180	50	200	230	70	0,65	24
REC in linea 220 EC	220	61	340	230	106	0,90	26
REC in linea 180 AC	180	50	200	230	70	0,65	24
REC in linea 220 AC	220	61	340	230	106	0,90	26

* Lp(A) measured at 3m in open field 230V-50Hz.

MODELS

Complete range composed of 3 models for houses up to 8 rooms:



REC in linea 140

- Ideal for houses up to **4 rooms** and average surface of 80 sqm.
- Installation configuration: **2 intake points and 2 extract points.**
- Max airflow **140 m³/h.**
- Integral by-pass.
- EC motors.



REC in linea 180

- Ideal for houses up to **6 rooms** and average surface of 100 sqm.
- Installation configuration: **3 intake points and 3 extract points.**
- Max airflow **180 m³/h.**
- Integral by-pass.
- AC or EC motors.



REC in linea 220

- Ideal for houses up to **8 rooms** and average surface of 120 sqm.
- Installation configuration: **4 intake points and 4 extract points.**
- Max airflow **220 m³/h.**
- Integral or separated by-pass.
- AC or EC motors.





REC IN LINEA TC

Centralized Heat Recovery Units Horizontal installation

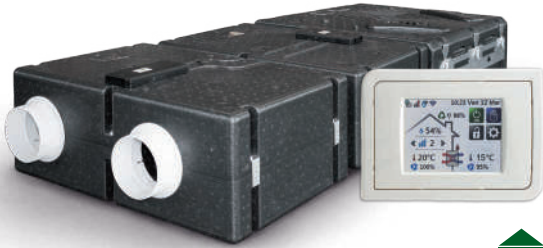

2 - 8 rooms

Energy Class A



Comply with ErP Directive 2009/125/CE and EU Regulation 1253/2014 Residential Ventilation Unit.

- Thermal efficiency up to **91%**
- Tested by **BRE according to EN308**
- Integrated by-pass
- EC motors

CONTROLLERS

REC In Linea TC is supplied with a remote Touch Panel controller with coloured screen. The panel allows to manually or automatically manage (through the weekly programming) the following functions:

- The Speed/ventilation level regulation
- The ventilation modality (by-pass function, free-cooling, only extraction, only immission)
- The threshold humidity level over which the unit increases its speed
- The post-ventilation function (Timer function, adjustable from 0 to 30 minutes) to delay the switching of the unit at the minimum speed)
- The Sleep modality that allow to have the unit running silently at low speed during the night



FEATURES

- High efficiency centralized heat recovery units with thermal efficiency up to 91%.
- Compact and modular.
- Horizontal installation in false ceilings.
- Lightweight and easy to install.
- Suitable for \varnothing 125 mm ducting system.
- Made in PPE for a perfect thermal and acoustic insulation.
- Provided with integrated by-pass.
- Multispeed high efficiency EC brushless motors.
- Low sound level.
- Filters class M6 in addition to the filters assembled.
- Supplied with fixing plate, and RLS 1WR control panel (EC motor versions).
- IPX2.
- Comply with EN 60335-2-80, B.T. 2014/35/UE, EMC 2014/30/UE
- Performance measured by BRE according to EN 13141-7, EN 13101-4, EN 5801 and EN 308.
- CE marked

PERFORMANCE

MODEL	AIRFLOW MAX		PRESSURE MAX	V at 50 Hz	W max	A max	dB(A)*
	m ³ /h	l/s	Pa				
REC in linea 140 EC Plus TC	140	39	210	230	50	0,55	24
REC in linea 180 EC Plus TC	180	50	200	230	70	0,65	24
REC in linea 220 EC Plus TC	220	61	340	230	106	0,90	26

* Lp (A) measured at 3 m in open field 230V 50 Hz

MODELS

Complete range composed of 3 models for houses up to 8 rooms:



REC IN LINEA 140 TC

- Ideal for houses up to **4 rooms** and average surface of 80 sqm.
- Installation configuration: **2 intake points and 2 extract points.**
- Max airflow **140 m³/h.**



REC IN LINEA 180 TC

- Ideal for houses up to **6 rooms** and average surface of 100 sqm.
- Installation configuration: **3 intake points and 3 extract points.**
- Max airflow **180 m³/h.**



REC IN LINEA 220 TC

- Ideal for houses up to **8 rooms** and average surface of 120 sqm.
- Installation configuration: **4 intake points and 4 extract points.**
- Max airflow **220 m³/h.**



CURVES

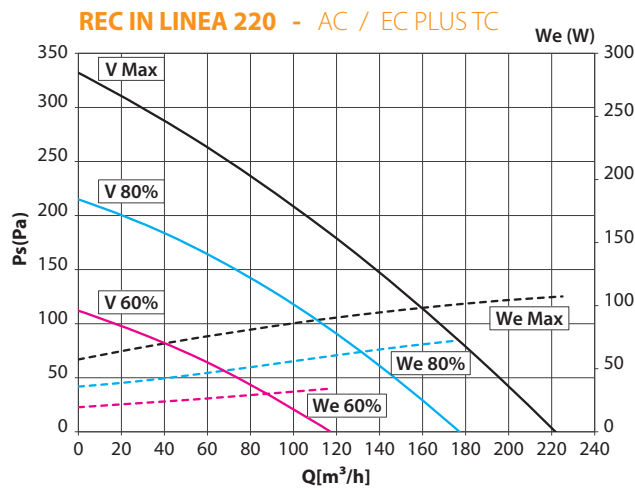
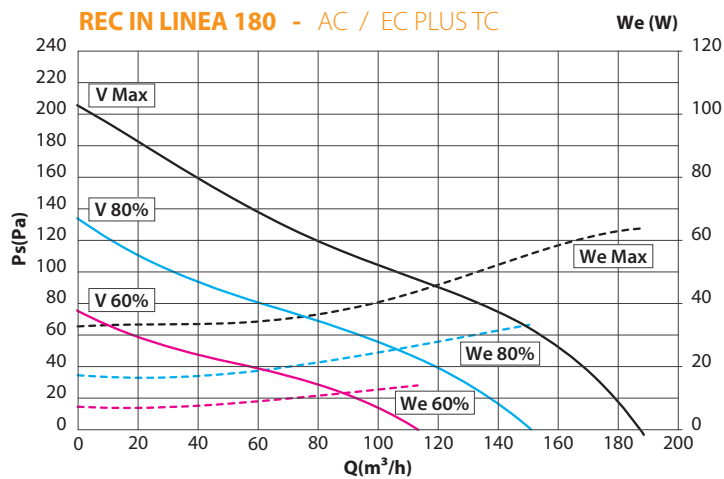
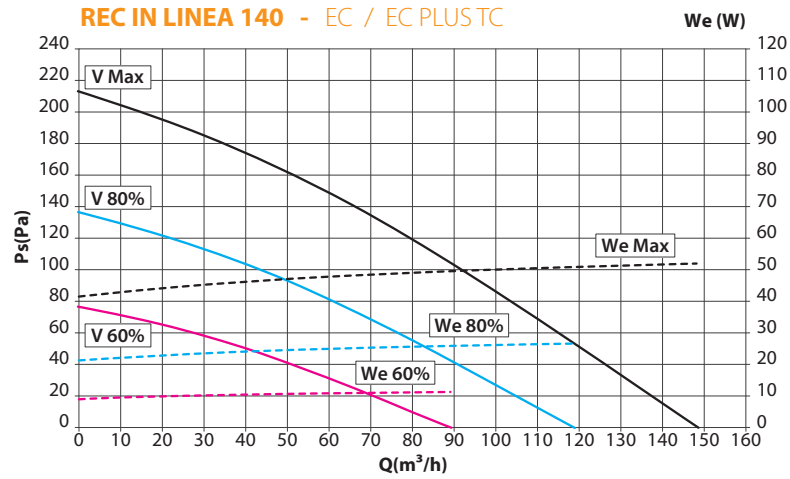

DIMENSIONS (mm)

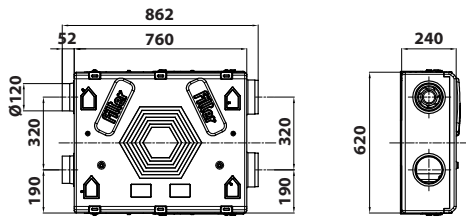

REC in linea 140
REC in linea TC 140
Kg. 13

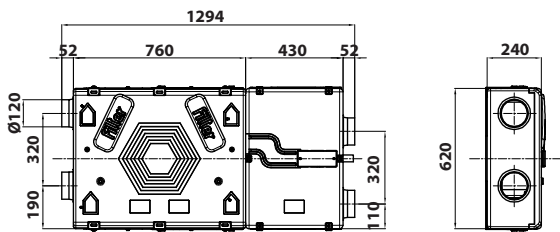
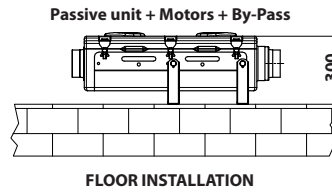
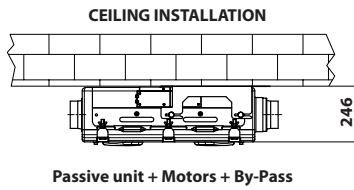

REC in linea 180
REC in linea TC 180
Kg. 18,5

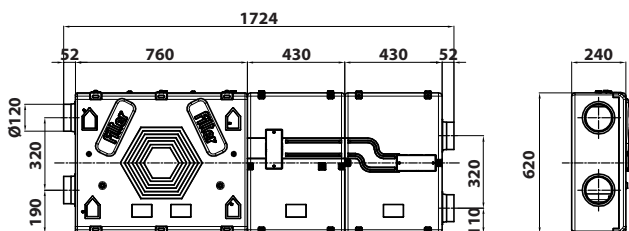
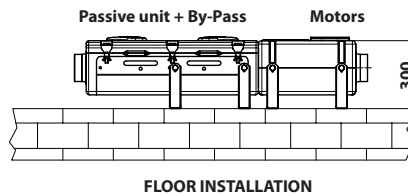
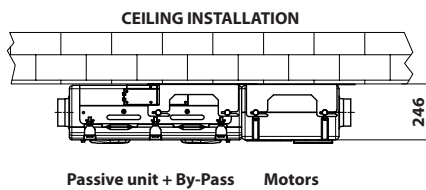

REC in linea 220
REC in linea 220 TC
Kg. 22

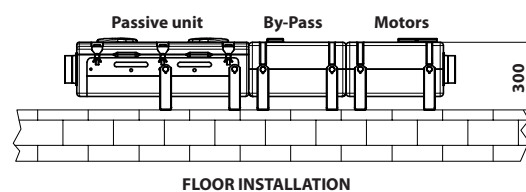
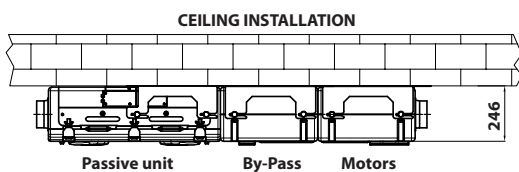



REC 280 - 320

Centralized Heat Recovery Units Vertical installation



FEATURES

- Centralized heat recovery unit for vertical installation.
- Suitable for \varnothing 125 mm ducting system.
- Casing made in galvanized steel sheet with epoxy finish
- Internal panels in PPE for a perfect thermal and acoustic insulation.
- Integrate or optional by-pass.
- Multispeed high efficiency motors.
- Low sound level.
- Integrated filter system class G4.
- Supplied with RLS 1WR control panel (EC motor versions).
- IPX4.
- Comply with EN 60335-2-80, B.T. 2006/95/CE, EMC 2004/108/CE
- Performance measured by BRE according to EN 13141-7, EN 13101-4, EN 5801 and EN 308.

Up to 10 rooms

Energy class A (REC 320)

- Thermal efficiency up to **93%**
- High energy saving thanks to EC motors



Comply with ErP Directive 2009/125/CE and EU Regulation 1253/2014 Residential Ventilation Unit.

CONTROLLERS

SUPPLIED

RLS 1 WR

- Remote control
- Manual selection of three modality of continuous running:
 - I - Low ventilation modality
 - II - Intermediate ventilation modality
 - III - Intensive ventilation modality
- Supply voltage 230V - 50/60 Hz
- Weight 0,50 Kg
- Dimensions 75 x 75 x 30



Supplied with REC 320

ACCESSORY

RLS 3V - 3 speeds

- Remote 3 speed control (Min/Max) and On/Off switch
- New design with cover
- Suitable for surface or built-in installation
- Ease of connection by the means of removable terminals
- Protection IP42
- Weight 0,40 Kg
- Supply voltage 230V - 50/60 Hz
- Dimensions 110 x 80 x 42



Suitable for REC 280

PERFORMANCE

MODEL	m ³ /h max	l/s max	V	W max	A max	dB (A)*	Kg
REC 280 AC	280	78	230	236	1	26	27,5
REC 320 EC	320	89	230	70	1,20	26	28

* Lp(A) at 3 m in open field at the maximum aerualic efficiency point (min. speed AC version and speed setting 60% EC version)

MODELS



REC 280 AC

- Provided with external rotor motor and forward blade impeller 2 speed running: continuous running at the minimum speed, maximum speed is activated through remote control.
- Ideal for houses up to **10 rooms**.
- Installation configuration: **5 intake points and 5 extract points.**
- Max airflow **280 m3/h**.
- High efficiency heat recovery: **93%**.
- Made in steel with epoxy finish.
- Ducting system \varnothing 125 mm.
- Integrated filter system class G4, easily removable.
- **Integrated by-pass.**
- **AC motor.**



REC 320 EC

- Provided with brushless motor for an optimal combination between high performance, silence and low energy consumption.
- Ideal for houses up to **10 rooms**.
- Installation configuration: **5 intake points and 5 extract points.**
- Max airflow **320 m3/h**.
- High efficiency heat recovery: **93%**.
- Made in steel with epoxy finish.
- Ducting system \varnothing 125 mm.
- Integrated filter system class G4, easily removable.
- **Integrated by-pass.**
- **EC motor.**



CURVES

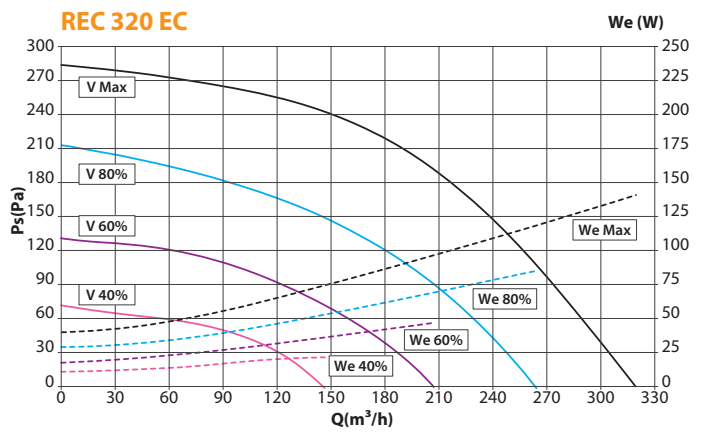
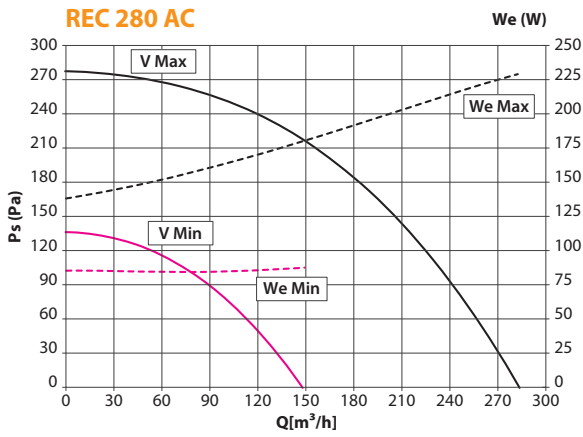

DIMENSIONS (mm)

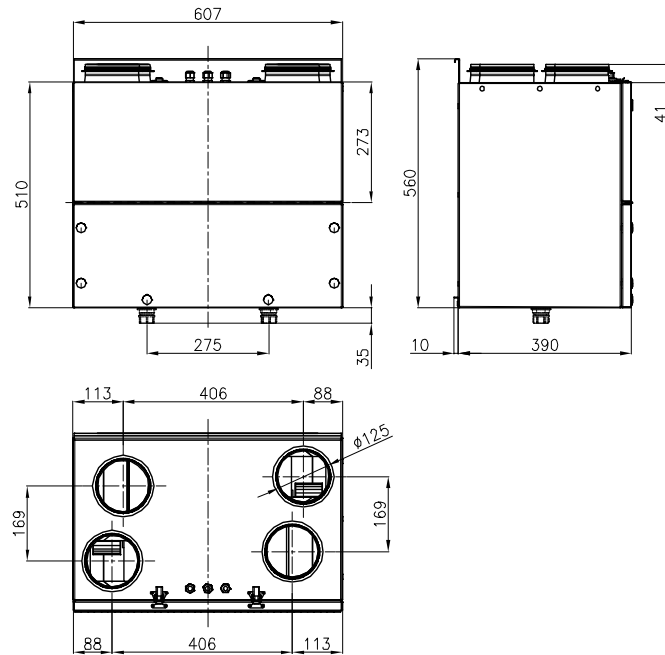

EFFICIENCY GRAPH

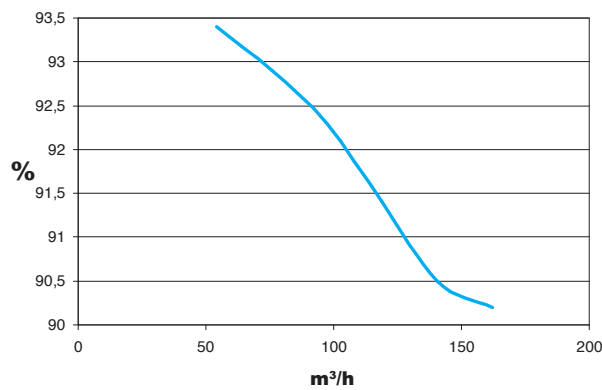



REC 320 TC

Centralized Heat Recovery Units Vertical installation



Up to 10 rooms

Energy class **A**

- Thermal efficiency up to **93%**
- Tested by BRE according to EN308
- Integrated by-pass



Comply with ErP Directive 2009/125/CE and EU Regulation 1253/2014 Residential Ventilation Unit.

REC 320 TC is supplied with a remote Touch Panel controller with coloured screen. The panel allows to manually or automatically manage (through the weekly programming) the following functions:

- The Speed/ventilation level regulation
- The ventilation modality (by-pass function, free-cooling, only extraction, only immission)
- The threshold humidity level over which the unit increases its speed
- The post-ventilation function (Timer function, adjustable from 0 to 30 minutes) to delay the switching of the unit at the minimum speed
- The Sleep modality that allow to have the unit running silently at low speed during the night

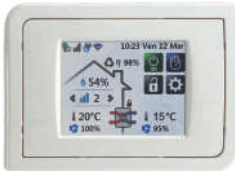

FEATURES

- High efficiency centralized heat recovery unit with thermal efficiency up to 93%.
- Provided with brushless motor for an optimal combination between high performance, silence and low energy consumption.
- Ideal for houses up to 10 rooms.
- Installation configuration: 5 intake points and 5 extract points.
- Max airflow 320 m³/h.
- Centralized heat recovery unit for vertical installation.
- Suitable for ø 125 mm ducting system.
- Casing made in galvanized steel sheet with epoxy finish
- Internal panels in PPE for a perfect thermal and acoustic insulation.
- Integrate or optional by-pass.
- Multispeed high efficiency motors.
- Low sound level.
- Integrated filter system class G4.
- Supplied with control panel
- IPX4.
- Comply with EN 60335-2-80, B.T. 2006/95/CE, EMC 2004/108/CE
- Performance measured by BRE according to EN 13141-7, EN 13101-4, EN 5801 and EN 308.
- CE marked

PERFORMANCE

MODEL	m ³ /h max	l/s max	V	W max	A max	dB (A)*	Kg
REC 320 EC PLUS TC	320	89	230	100	0,90	26	28

* Lp(A) at 3 m in open field

CURVES

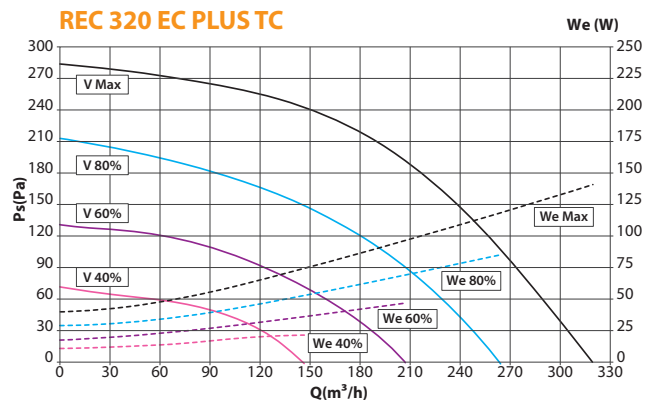

DIMENSIONS (mm)

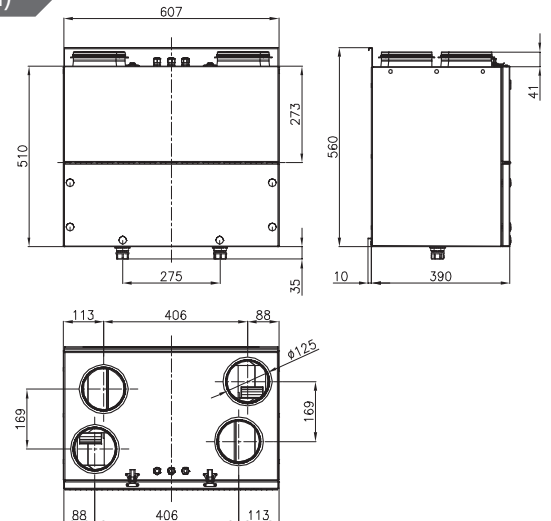

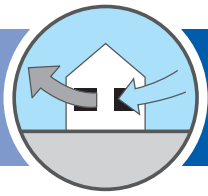

RESIDENTIAL AND COMMERCIAL EXTRACT VENTILATION

Centralized extract ventilation

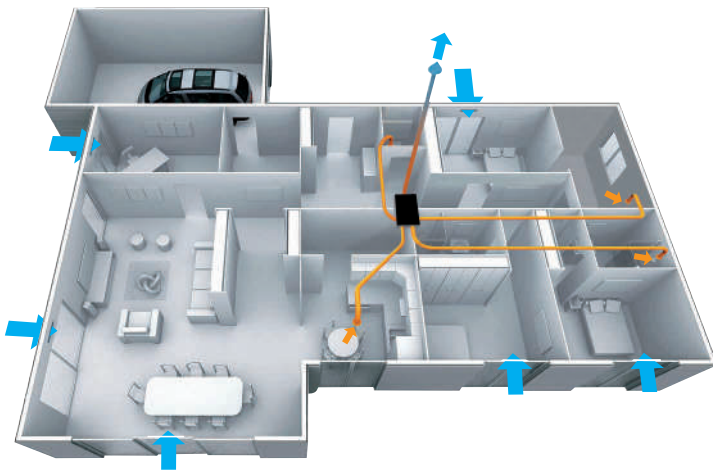

High efficiency central ventilation solutions for air extract: the stale air is exhausted from humid rooms (kitchen, bathroom, toilets, laundry). The fresh air is supplied by specific air entrance points.

- High energy efficiency with EC motors.
- Designed for ease of installation and low noise running
- All models available with EC motors. 



MICROBOX

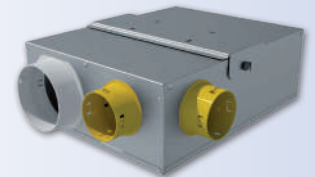

MULTIBOX

Decentralized extract ventilation - Design and Performance



AXIAL FANS

Axial fans are designed to extract large volumes of low pressure air directly to the outside or over short duct lengths. They can be suitable for wall, window, duct and ceiling application.

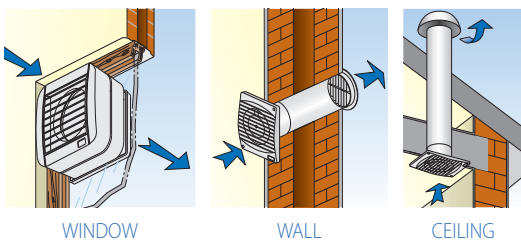

CENTRIFUGAL FANS

Centrifugal fans are designed to extract air over long distances and to overcome the resistance of long length and curved ducting. They are suitable for wall, ceiling, roof installation, in single or multiple ducts.

DUCT INSTALLATION

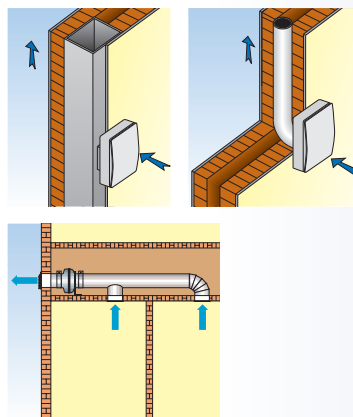

OUTDOOR INSTALLATION

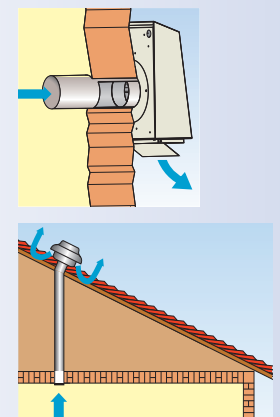



MICROBOX

Whole-house mechanical extract ventilation Super-slim centrifugal box



Comply with ErP Directive and UE Regulation 1253/2014 Ventilation Unit (VU)

- High energy saving
- SUPER-SLIM
- Extreme ease of installation and maintenance
- All versions are speed controllable

CONTROLLERS



RLS 3V
Suitable for
Microbox 3V See pag. 79



CP
Suitable for
Microbox Control See pag. 79



CP-RH See pag. 80
Supplied with
Microbox Control+ HY
and **Microbox EC HY**



CP-AQS See pag. 80
Supplied with
Microbox Control+ AQS
and **Microbox EC AQS**

MODELS	CONFIGURATION	MOTOR	m³/h	l/s	W	A	dB(A)*
			max	max	max	max	
MICROBOX 3V (1)	80/125	AC	101/175/246	28/47/68	13/25/49	0,13/0,18/0,22	41
MICROBOX CONTROL (1)	80/125	AC	246	68	84	0,75	49
MICROBOX CONTROL+ HY	80/125	AC	246	68	84	0,75	49
MICROBOX CONTROL+ AQS	80/125	AC	246	68	84	0,75	49
MICROBOX EC HY	80/125	EC	310	86	84	0,75	49
MICROBOX EC AQS	80/125	EC	310	86	84	0,75	49
MICROBOX 3V (1)	3X80/125	AC	101/175/246	28/47/68	13/25/49	0,13/0,18/0,22	41
MICROBOX CONTROL (1)	3X80/125	AC	246	68	84	0,75	49
MICROBOX CONTROL+ HY	3X80/125	AC	246	68	84	0,75	49
MICROBOX CONTROL+ AQS	3X80/125	AC	246	68	84	0,75	49
MICROBOX EC HY	3X80/125	EC	310	86	84	0,75	49
MICROBOX EC AQS	3X80/125	EC	310	86	84	0,75	49

Lp(A) measured at 3 m in open field 230V-50Hz
(1) Available for extra UE markets only

CURVES

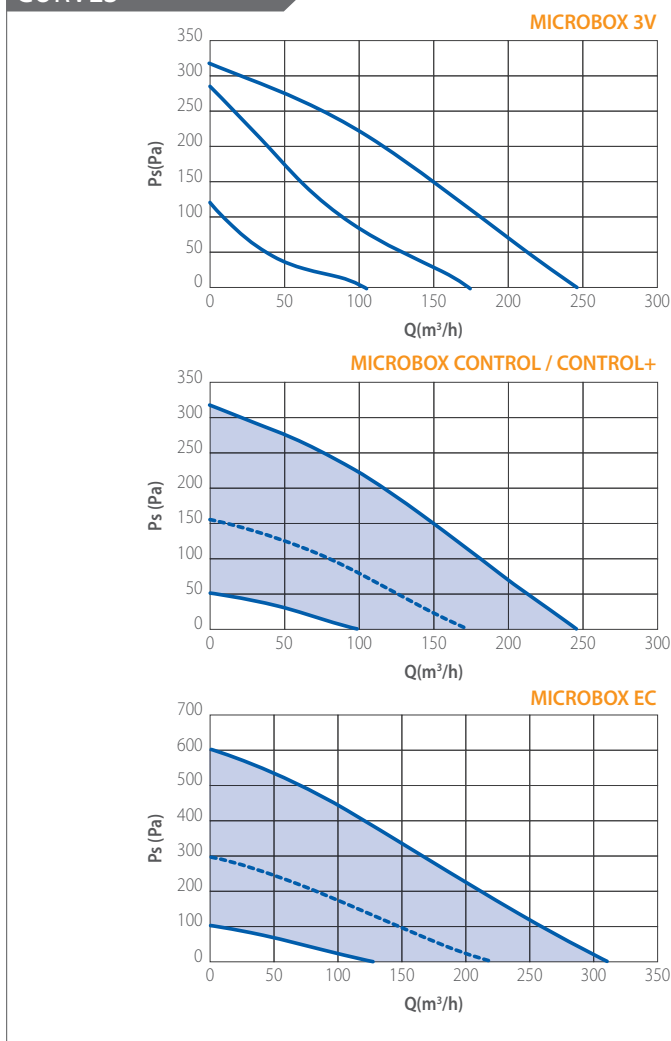

DIMENSIONS (mm)

TYPE	A	B	C	D	ØE	ØF	Kg
MICROBOX	241	384	448	135	125	80	5,8

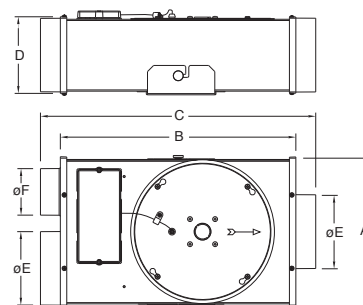



MULTIBOX

Whole-house mechanical extract ventilation Multiport centrifugal box

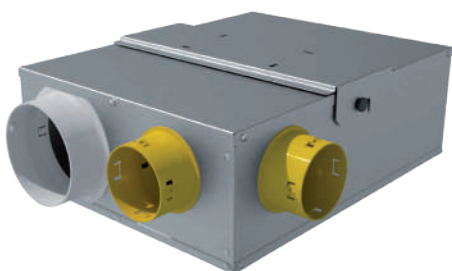

MODELS	CONFIGURATION	MOTOR	m³/h	l/s	W	A	dB(A)*
			max	max	max	max	max
MULTIBOX 3V (1)	3X80/125	AC	153/198/348	42,5/55/97	14/23/47,5	0,12/0,16/0,21	35
MULTIBOX CONTROL (1)	3X80/125	AC	348	97	47,5	0,21	37
MULTIBOX CONTROL+ HY	3X80/125	AC	348	97	47,5	0,21	37
MULTIBOX CONTROL+ AQS	3X80/125	AC	348	97	47,5	0,21	37
MULTIBOX EC HY	3X80/125	EC	460	128	85	0,77	37
MULTIBOX EC AQS	3X80/125	EC	460	128	85	0,77	37

Lp(A) measured at 3 m in open field 230V-50Hz
(1) Available for extra UE markets only



Comply with ErP Directive and
UE Regulation 1253/2014
Ventilation Unit (VU)

- High energy saving
- Provided with 3xØ80 + 1xØ125 mm inlet spigots and 1xØ125mm outlet spigot
- Silent operation
- Extreme ease of installation and maintenance
- Silent operation thanks to acoustic insulation lining
- All versions speed controllable

CONTROLLERS



RLS 3V
Suitable for
Multibox 3V See pag. 79



CP
Suitable for
Multibox Control See pag. 79



CP-RH See pag. 80
Supplied with
Multibox Control+ HY
and **Multibox EC HY**



CP-AQS See pag. 80
Supplied with
Multibox Control+ AQS
and **Multibox EC AQS**

CURVES

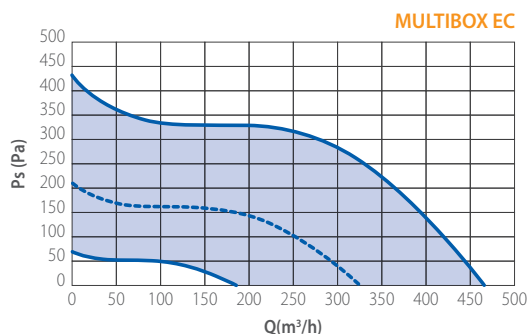
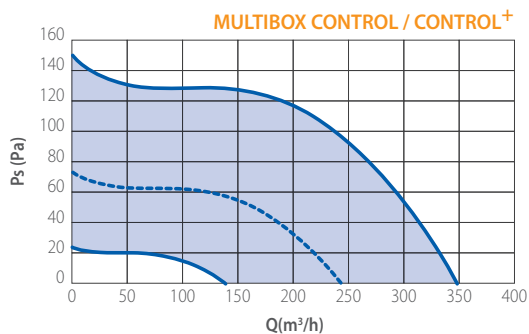
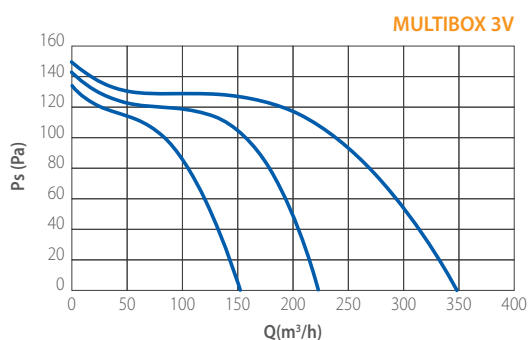

DIMENSIONS (mm)

TYPE	A	B	C	D	ØE	ØF	Kg
MULTIBOX	345	437	523	174	125	80	6,2

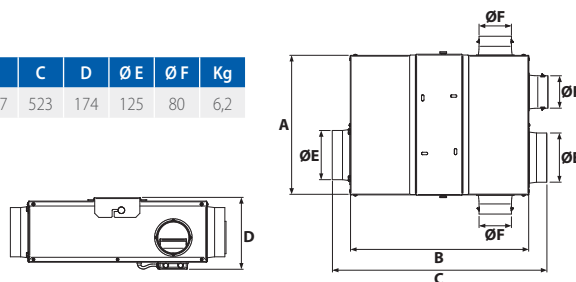



AXM

Mixed flow In-line duct fans



MODELS	m ³ /h	l/s	W	A	dB(A)* at 3 m	
					Lw	Lp
AXM 100	160/250	44/69	35	0,1/0,18	55	39
AXM 125	180/300	50/83	36	0,1/0,18	54	44
AXM 150	340/480	94/133	70	0,27/0,36	66	50
AXM 160	340/480	94/133	70	0,27/0,36	65	50
AXM 200	720/820/910	200/228/253	75	0,24/0,27/0,34	58	43

* Lp(A) measured at 3m in open field 230V-50Hz.



Comply with ErP Directive 2009/125/CE and EU Regulation 327/2011. Classification FAN.

- Duct fans, entirely made of polypropylene.
- For direct installation between ducts.
- Easy inspection and maintenance by simply opening the clamp and removing the fan.
- Helicentrifugal mixed flow impeller with downstream stator. Made in ABS.
- Asynchronous motor, 2 and 3 speeds, depending on model.
- IP 44 Protection, Motor Class B.
- Robust motor with ball bearings, maintenance-free.
- 220 - 240 V at 50 Hz.
- Speed control using phase control or transformer (exception: Version with timer).
- Thermal overload protection as a standard feature.
- Externally fitted terminal box with cable entry grommet.

BENEFITS

- High efficiency resulting in minimum energy costs.
- Quiet running thanks to optimized aerodynamics and guide vanes.
- Easy installation: pre-installed mounting brackets and external connection box.
- Simplified maintenance by loosening the clamps (no need to handle the duct).
- Versatile installation.



VERSIONS

Timer

CONTROLLERS

ACCESSORIES

R 10

Electronic speed controller
max load 1A

See pag. 79



RVS

5 steps speed controller with transformer
max load 0,5 A

See pag. 79



AXM 100

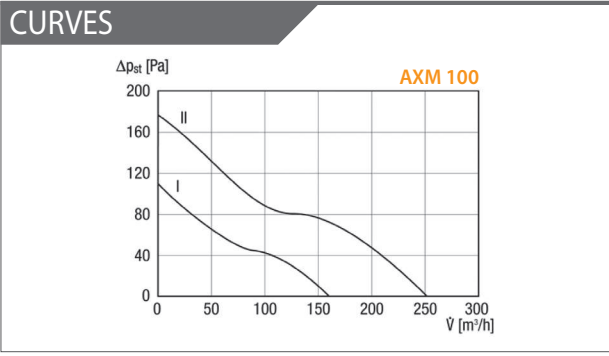
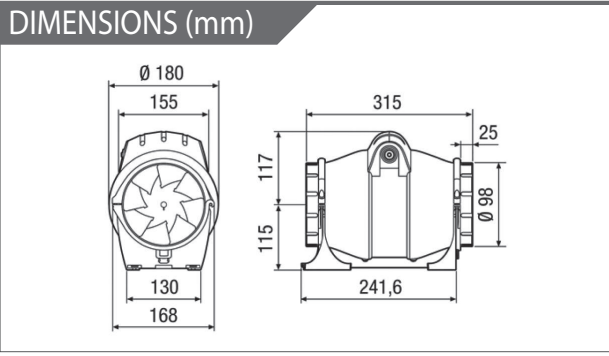

AXM 125

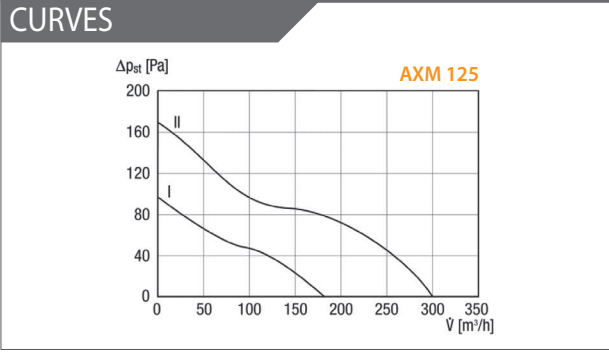
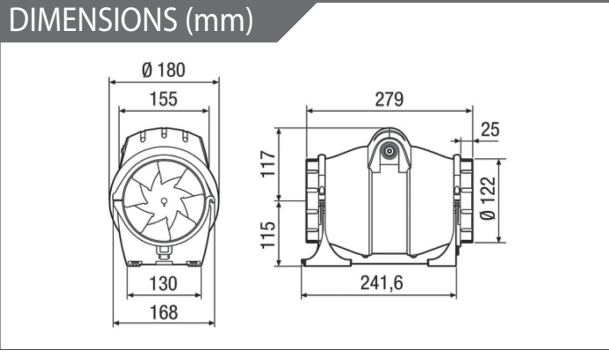

AXM 150

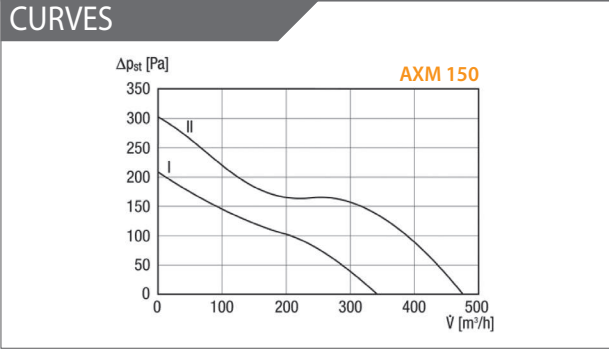
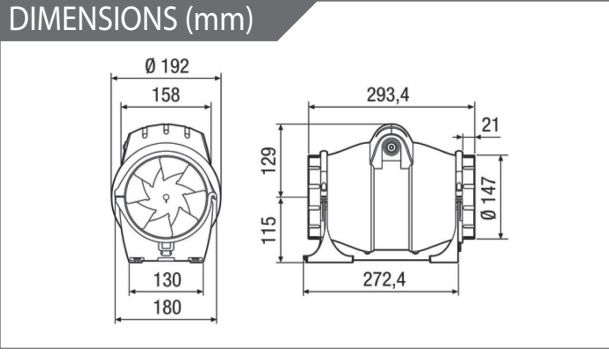

AXM 160

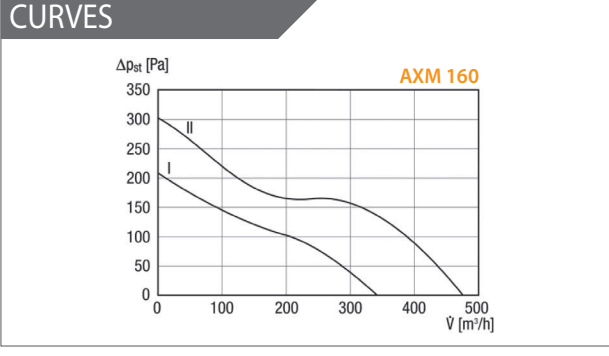
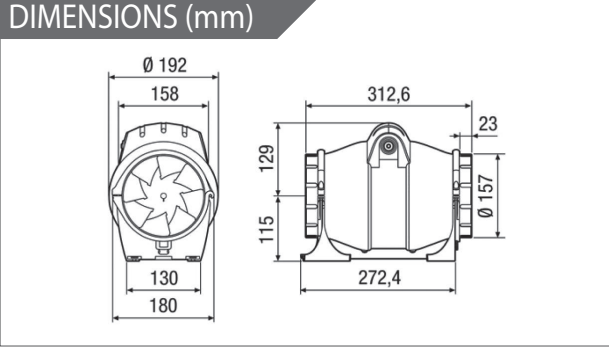

AXM 200

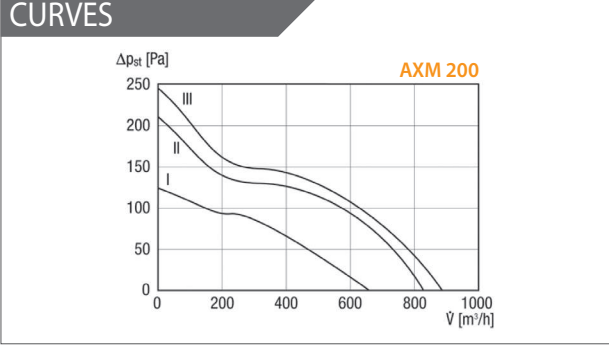
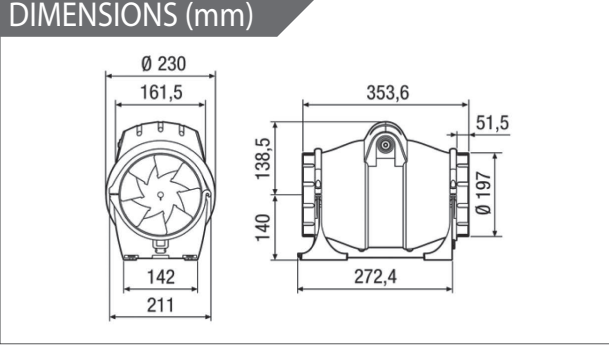



PERFORMANCES

MODELS	m ³ /h	l/s	Pa	W	A	dB(A)*
EXT 100	217	60	268	28	0,13	44
EXT 125	269	75	259	28	0,13	44
EXT 150 A	426	118	322	56	0,24	56
EXT 150 B	708	197	467	110	0,48	59
EXT 160 A	433	120	309	56	0,24	56
EXT 160 B	755	210	480	120	0,53	61
EXT 200 A	793	220	486	120	0,53	61
EXT 200 B	908	252	609	158	0,70	65

*LpA measured at 3m in open field 230V-50Hz.



Comply with ErP Directive 2009/125/CE and UE Regulation 1253/2014. Residential Ventilation Unit. To comply with the ErP2018 parameters, a local demand controller must be used.

- High performance centrifugal fans for outdoor installation.
- Ideal in environments where aesthetics, space or noise level are of concern.
- Easy and cost-effective solution for a centralized ventilation requirement.
- 8 models Ø100 to 200 mm
- Steel housing with epoxy finish.
- Ball bearing motor. Backward curved blades.
- EC Version available

INSTALLATION

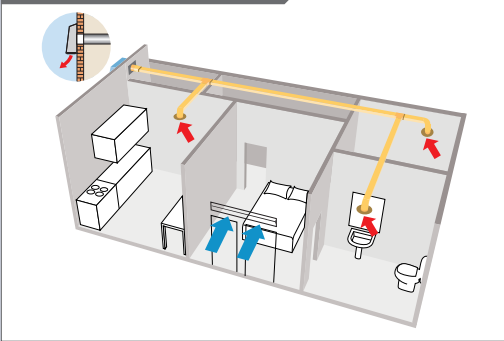

DIMENSIONS

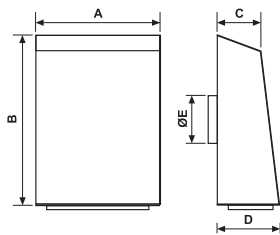

MODELS	A	B	C	D	ØE	Kg
EXT 100	260	355	92	131	98	4,8
EXT 125	260	355	92	131	122	4,8
EXT 150 A	260	355	92	131	148	5
EXT 150 B	360	450	116	155	148	7,4
EXT 160 A	260	355	92	131	158	5
EXT 160 B	360	450	116	155	157	7,4
EXT 200 A	360	450	116	155	198	7,4
EXT 200 B	360	450	116	155	198	7,4

CURVES

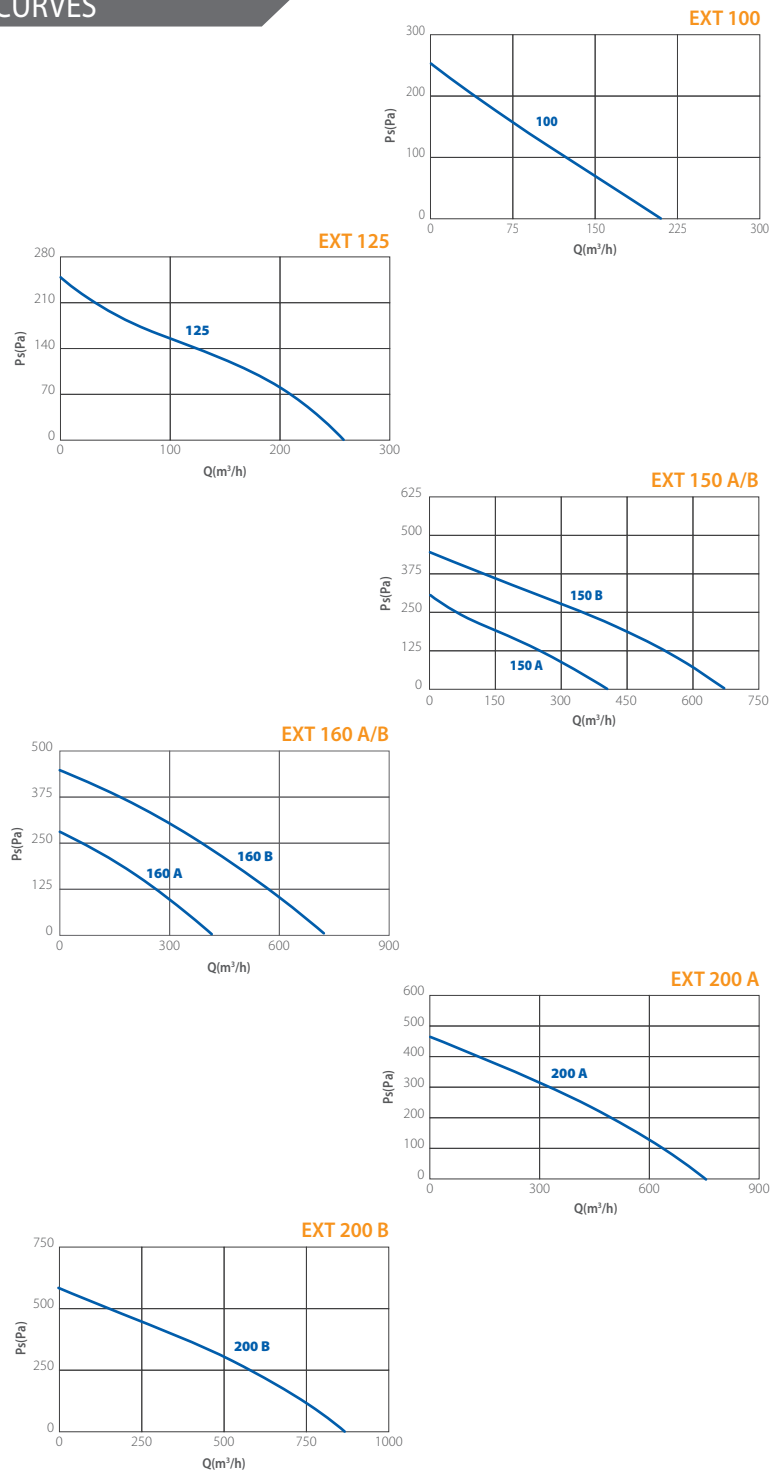



PERFORMANCES

MODELS	m ³ /h	l/s	Pa	W	A	dB(A)*
MRF 100	318	88	415	74	0,22	52
MRF 125	342	95	395	75	0,22	52
MRF 150	579	161	459	80	0,37	52
MRF 160	736	204	515	116	0,47	54
MRF 200	794	280	503	200	0,48	55
MRF 250	866	240	602	203	0,65	51
MRF 315	1222	339	838	247	1,10	55

*LpA measured at 3m in open field 230V-50Hz.



Comply with ErP Directive 2009/125/CE and UE Regulation 1253/2014. Residential Ventilation Unit. To comply with the ErP2018 parameters, a local demand controller must be used.

- High performance centrifugal fans for roof installation.
- Compact sizes, available with or without square roof curb.
- Easy and cost-effective solution for a centralized ventilation requirement.
- 7 models Ø100 to 315 mm
- Made in aluminium and steel sheet with epoxy finish, highly resistant to atmospheric agents.
- Ball bearing motor.
- EC Version available 

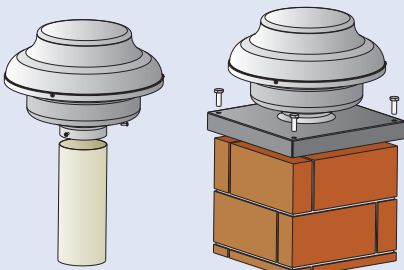

MRF

MRF/BA

MODELS

- MRF
- MRF with square roof curb

INSTALLATION

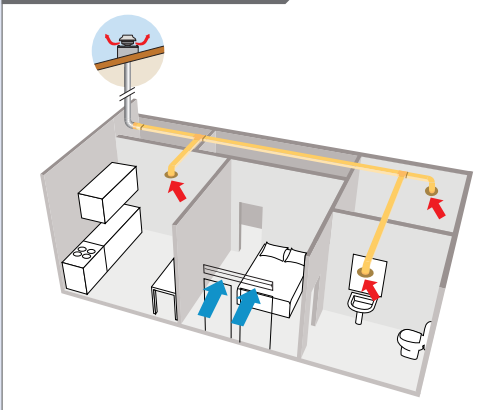

CURVES

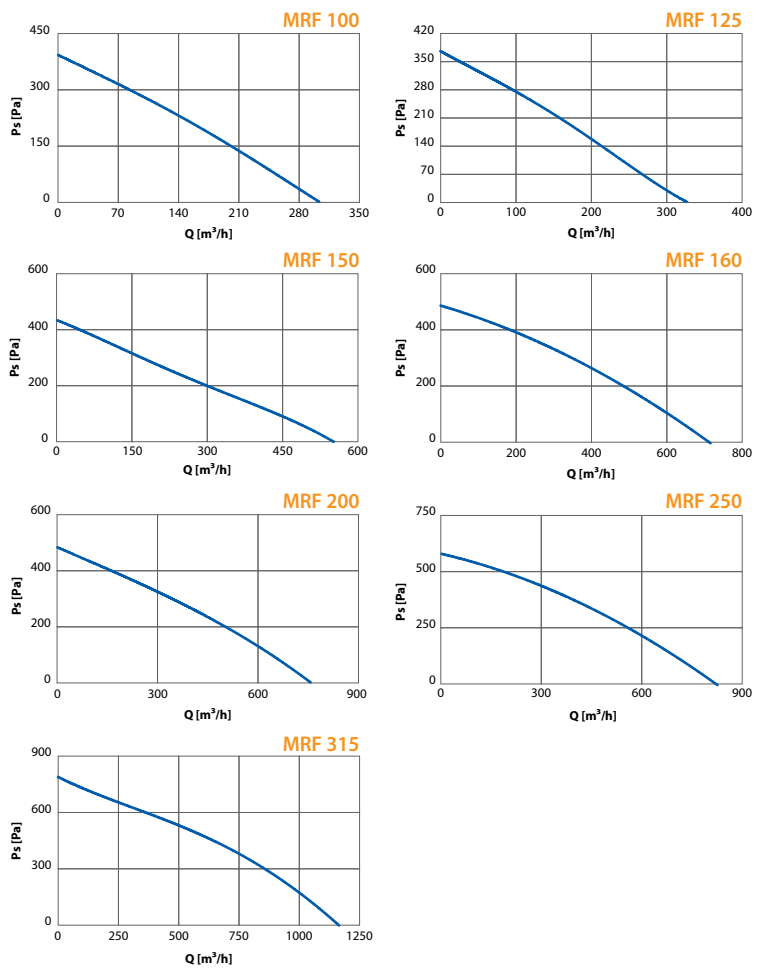

DIMENSIONS (mm)

MODELS	D1	D2	H	∅A	∅B	C	Kg	Kg*
MRF100	98	333	225	300	265	36	3,1	4,6
MRF125	122	333	225	300	265	36	3,1	4,6
MRF150	147	405	266	400	360	36	4,2	6,2
MRF160	157	405	266	400	360	36	5	6,2
MRF200	198	405	266	400	360	36	5,5	6,8
MRF250	248	405	266	400	360	36	6	7,3
MRF315	314	484	322	400	360	36	7	10

* Models with square roof curb

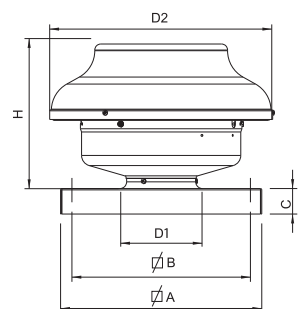



AXC

Centrifugal in-line duct fans Metal Version



PERFORMANCES

MODELS	m ³ /h	l/s	Pa	W	A	dB(A)*
AXC 100 A	237	66	279	27	0,13	30
AXC 100 B	260	72	383	50	0,23	36
AXC 125 A	287	80	238	27	0,13	32
AXC 125 B	313	87	345	50	0,23	36
AXC 150 A	337	94	189	29	0,14	33
AXC 150 B	537	149	406	80	0,37	39
AXC 160 A	365	101	203	29	0,14	31
AXC 160 B	754	209	476	110	0,50	38
AXC 200	887	246	460	110	0,50	34
AXC 250	1114	309	543	150	0,65	43
AXC 315	1439	400	742	260	1,14	43
AXC 355 A **	2200	611	349	240	1,12	57
AXC 355 B **	2350	653	902	650	2,82	77

*LpA measured at 3m in open field 230V-50Hz. **Available for extra UE markets only without CE marking.



Comply with ErP Directive 2009/125/CE and UE Regulation 1253/2014. Residential Ventilation Unit. To comply with the ErP2018 parameters, a local demand controller must be used.

- High performance centrifugal fans for in-line duct installation.
- Easy and cost-effective solution for a centralized ventilation requirement.
- 11 models Ø100 to 315 mm.
- Steel housing with epoxy finish inside and outside.
- Ball-bearing motor. Backward curved blades.
- Impeller in tecnopolymer up to size 250 - Metal on size 315-355.
- EC Version available

SUPPLIED

Wall fixing brackets.



INSTALLATION

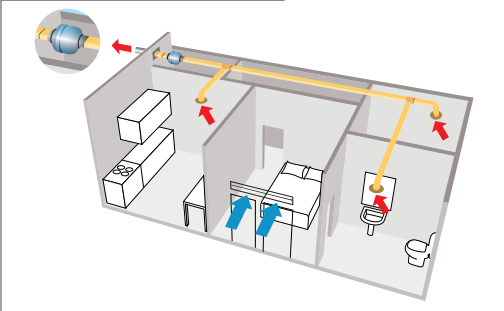

CURVES

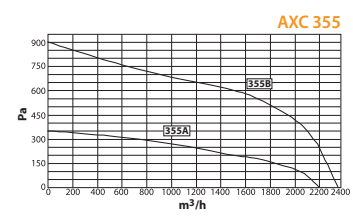
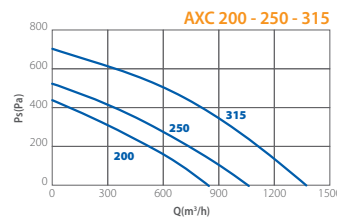
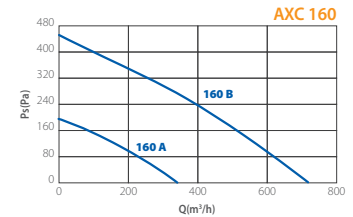
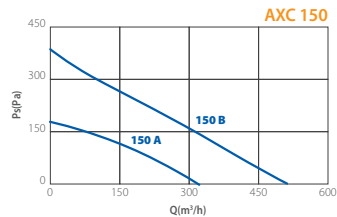
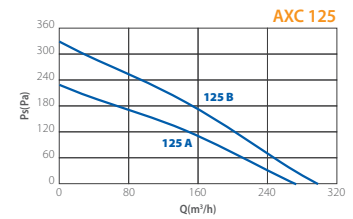
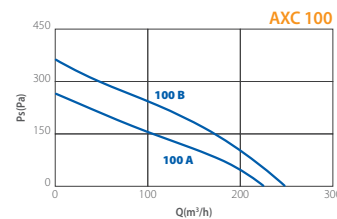

DIMENSIONS

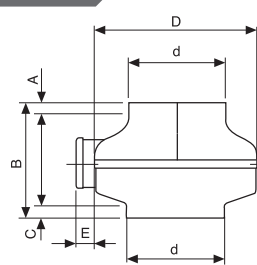

MODELS	A	B	C	ØD	Ød	E	Kg
AXC 100 A	12	215	24	245	98	38	3
AXC 100 B	12	215	24	245	98	38	3
AXC 125 A	11	214	24	245	122	38	3
AXC 125 B	11	214	24	245	122	38	3
AXC 150 A	21	216	23	245	147	38	3
AXC 150 B	22	230	22	333	148	38	5
AXC 160 A	24	215	24	245	157	38	3
AXC 160 B	21	230	22	333	158	38	5
AXC 200	22	230	27	333	198	38	5
AXC 250	22	230	35	333	248	38	5
AXC 315	30	297	52	404	314	38	8
AXC 355 A	44	400	50	484	355	38	12
AXC 355 B	44	400	50	484	355	38	14

INSTALLATION

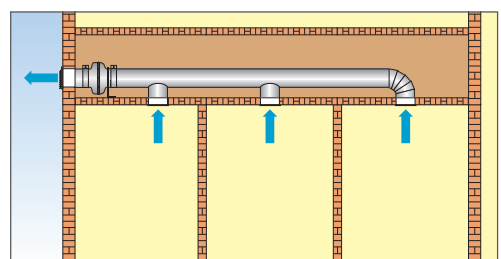
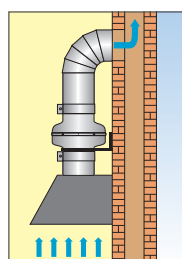
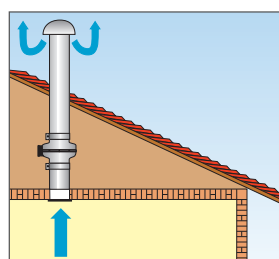
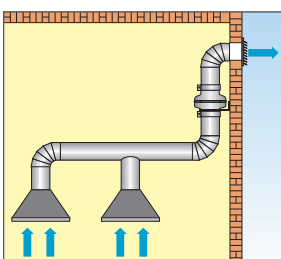



PERFORMANCES

MODELS	DUCT Ø mm	m³/h	l/s	Pa	A	W	dB (A)*
AXC 100 TP	100	211	58	263	0,127	27	36,1
AXC 125 TP	125	265	73	251	0,129	27	37,1
AXC 150 TP	150	415	115	301	0,290	65	38,1
AXC 160 TP	160	431	120	294	0,284	65	39,1

*LpA measured at 3m in open field 230V-50Hz.



Comply with ErP Directive 2009/125/CE and EU Regulation 1253/2014 (Classification: Residential Ventilation Unit).

- Lightweight and silent
- Made in self-extinguishing V2 technopolymer
- Backward curved blades and ball bearing motor provided with thermal cut-out
- 4 models with Ø from 100 to 160 mm
- IMQ mark on models 150 and 160

DIMENSIONS (mm)

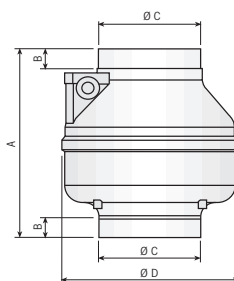

MODELS	A	B	Ø C	Ø D	Kg.
AXC 100 TP	238	25	98	212	1,5
AXC 125 TP	238	25	123	212	1,5
AXC 150 TP	232	28	147	253	2
AXC 160 TP	232	28	157	253	2

CURVES

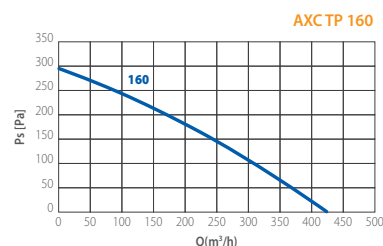
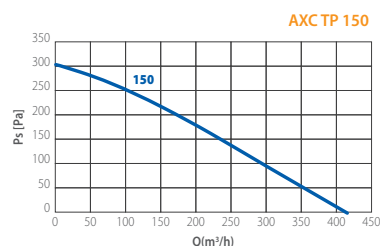
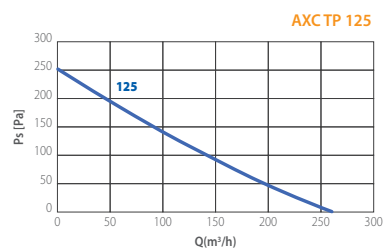
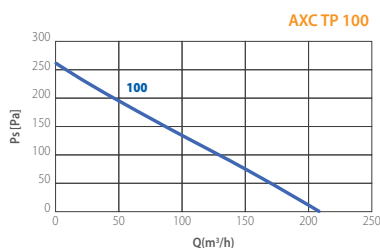

INSTALLATION

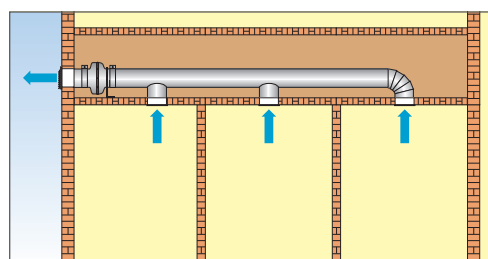
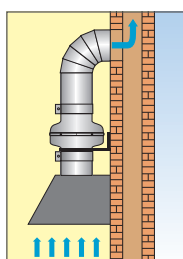
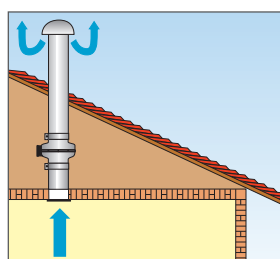
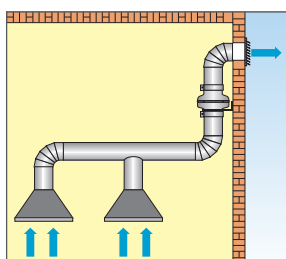

RESIDENTIAL AND COMMERCIAL EXTRACT VENTILATION

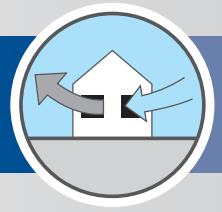

@max

MAXIMISE YOUR VENTILATION EXPERIENCE



NEW

OPTIMIZED DESIGN

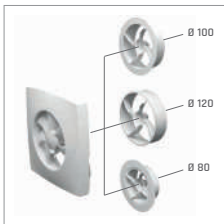

INTERCHANGEABLE OUTLET SPIGOTS

@max is supplied with 3 interchangeable spigots of Ø 80, 100 and 120 mm, replaceable with a click, for an easy and quick installation on any standard air duct sizes.



SILENT AND HIGHLY EFFICIENT IMPELLER

The advanced aerodynamic design of the impeller, which is also provided with an antivibration gasket, combines high airflow capacity and the lowest noise level between, 15 and 29 dBA at the maximum performance.



DETACHABLE MOTOR-IMPELLER

The frame is featured with a quick connection in order to facilitate and speed up the fan installation or maintenance without the use of tools.



INTEGRATED SERVICE SWITCH

@max is equipped with an integrated on/off slide switch for a quick disconnection to power mains and a safe maintenance operation.



INTEGRATED SMART FUNCTIONS

@max is provided with different integrated smart functions which optimize its operation and reduce the energy consumption.



OPTIMIZED EFFICIENCY

@max outlet spigots are provided with deflectors, optimized through a Computational Fluid Dynamic (CFD) analysis, to ensure a maximized efficiency.

@max IS THE INNOVATIVE UNIVERSAL AND MODULAR AXIAL FAN DESIGNED FOR A MAXIMIZED COMFORT VENTILATION IN SHOWER ROOMS, BATHROOMS, KITCHENS AND ANY RESIDENTIAL PREMISES WHERE INDOOR AIR QUALITY IS A MUST. ITS ADVANCED AND INTEGRATED CONTROL FUNCTIONS ALLOW SOLUTIONS TAILORED TO PERSONAL NEEDS: A SMART AND FRIENDLY INNOVATION AT THE SERVICE OF YOUR WELL-BEING.

MULTI-DIAMETER
Ø80-100-120

MULTI-TENSION
110-240V- 50/60HZ

ENERGY-SAVING
1 - 3.8W

SILENT
15 - 29 dBA



e max

Universal modular axial fan



Comply with ErP Directive 2009/125/CE and UE Regulation 1253/2014
Classification: Residential Ventilation Unit

- **Modular axial fan provided with 3 outlet spigots of Ø80 - Ø100 - Ø120 mm**
- Suitable for axial flow discharge towards the outside or through short ducts.
- Versatile installation on wall or ceiling.
- Very compact sizes and ultra-slim profile (33 mm without spigot), available with fixed grill.
- Equipped with an on/off service switch on board for a quick and safe disconnection from power mains.
- Integrated smart functions settable and controllable on board or via remote control according to versions.
- **Multi tension 110-240V 50-60Hz** ball bearing electronically commutated motor.
- Made of high quality antistatic technopolymer material.
- Optimized aerodynamic and fluid dynamic design.
- Impeller provided with an antivibration gasket.
- Aesthetic and smart LED on the cover with changing colors according to the ventilation modality.
- Back-draught shutters available on spigots (Ø 100 and 120).
- In compliance with EN 60335-2-80, EMC Directive 2014/30/UE, LVD Directive 2014/35/UE.

INSTALLATION

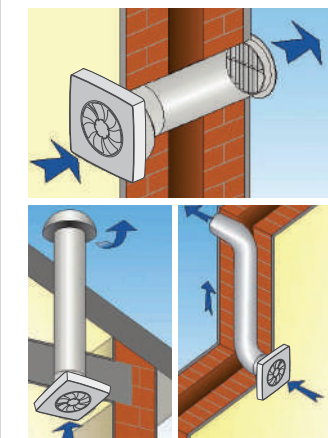

INCLUDING

REMOTE CONTROLLER INCLUDED WITH e max PLUS RC



PERFORMANCES

OUTLET DIAMETER	SPEED	A	POWER	AIR FLOW	l/s	PRESSURE	LpA@3m
			W	m³/h		Pa	dB(A)*
80	Max	0,034	3,6	65	18	50	29
	Medium	0,020	1,9	41	11	21	19
	Min	0,015	1,1	21	6	7	14
100	Max	0,034	3,6	104	29	53	30
	Medium	0,020	1,9	67	19	23	20
	Min	0,015	1,1	33	9	7	14
120	Max	0,035	3,8	129	36	59	28
	Medium	0,020	1,9	81	22,5	25	17
	Min	0,014	1,1	41	11	8	14

* Sound pressure calculated @ 3m in free field - Performance measured at 230V / 50 Hz

DIMENSIONS (mm)

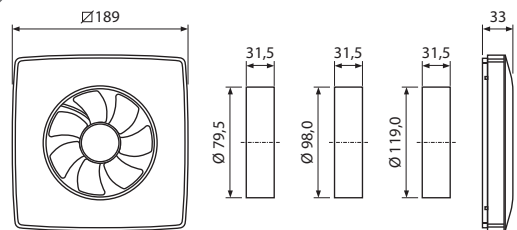

CURVES

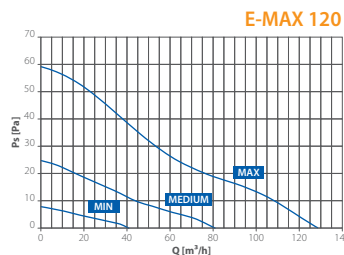
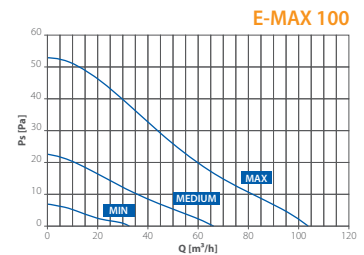
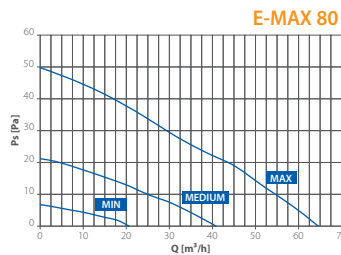

VERSIONS

STANDARD

On/Off via control switch (light or remote)

2V DT - 24 hours running at low speed (selectable between 2 at installation). Speed boosts to maximum via control switch (light or remote). The maximum speed is provided with a timer (adjustable from 0 to 30 minutes) which activation can be delayed up to 2 minutes to avoid unnecessary night-time operation at the highest speed. (DT/Delay Timer function, selectable at installation).

MHY - 24 hours running at low speed (not selectable). Speed boosts to maximum automatically or manually.

- **Automatically** via humidistat (adjustable from 45 to 85% of R.H). The fan speed increases/decreases according to the humidity level detected above the pre-selected threshold. It then switches back to the minimum speed when the humidity level goes beneath the pre-selected threshold and once concluded the pre-selected overrun via timer (adjustable from 0 to 30 min).

• **Manually** via control switch (light or remote). The fan boosts to maximum via the manual switch and goes back to the low speed once concluded the pre-selected overrun via timer (adjustable from 0 to 30 min).

PLUS - 24 hours running with minimum and maximum speeds both adjustable.
The operation is similar to the MHY version. In addition, the fan is provided with the DT/Delay Timer function (see E max 2V DT).

PLUS RC - This version is similar to the e max Plus one. In addition, it is supplied with a remote control from which it is possible to set 2 additional functions:

- an intermediate speed which will adjust automatically according to the minimum and maximum speeds selected.
- a sleep mode function that excludes the timer and humidistat functions for a period of 8 hours, preventing night disturbance.

PERFORMANCES

MODELS	m ³ /h	l/s	Pa	W	dB(A)*
E-SMILE	90	25	71	7,5	29,4
E-SMILE COMFORTIMER	90 / 60	25 / 17	71 / 44	7,5 / 5	29,4 / 19
E-SMILE COMFORT HYGRO	90 / 60	25 / 17	71 / 44	7,5 / 5	29,4 / 19
E-SMILE PIR	90	25	71	7,5	29,4
E-SMILE SELV	90	25	71	7,5	29,4

*Lp(A) measured at 3m in open field 230V-50Hz.



Comply with ErP Directive 2009/125/CE and EU Regulation 1253/2014 (Classification: Residential Ventilation Unit)

- To exhaust air directly to the outside or into a short length ducting (max 3 m length).
- Suitable for toilets, bathrooms, WC's, shower-rooms, utility rooms and kitchens.
- Unique model ø100 mm
- High aerualic performance
- Low consumption: from 5 to 7,5 W
- Suitable for medium length ducting
- Provided with ball bearing motor Long Life 30.000 hours and robust back-draught shutters

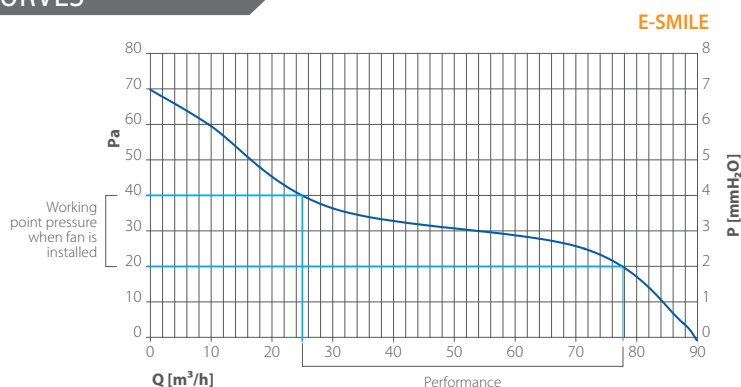
CURVES

VERSIONS

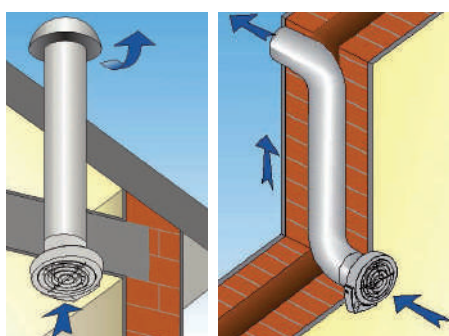
- STANDARD** - On/off through light or remote control switch
- PULL CORD** - On/off through pull cord switch
- TIMER** - Integral electronic timer adjustable from 3 to 25 minutes
- COMFORTIMER** - Overrun timer at low speed
- MHT** - Humidity control, adjustable from 40 to 80% of R.H.
- MHY** - Smart Humidity control automatic progressive increase/decrease of fan speed according to the percentage of R.H.
- PIR** - On/off via Passive infrared sensor
- 2 SPEED** - 24 hours running at the lowest speed
- SELV 12 V** - SELV 12 V a.c.

INSTALLATION

CEILING

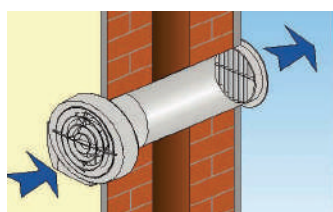
SINGLE DUCT

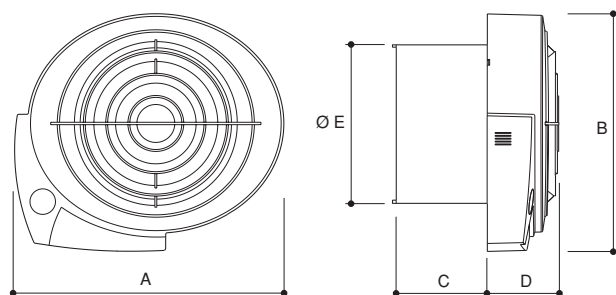

WALL

DIMENSIONS (mm)

MODEL	A	B	C	D	Eø	Kg
E-SMILE	168	150	57	45	99,8	0,67



PERFORMANCES

MODELS	PROTECTION	m³/h	l/s	Pa	W	dB(A)*
Standard - Timer - Pull cord - MHY smart						
ELEGANCE 100	IPX4	90	25	41	14	31,4
ELEGANCE 120	IPX4	165	46	54	15	36,7
ELEGANCE 150	IPX4	315	87	70	25	43,9
Comfortimer - 2 speed						
ELEGANCE 100	IPX4	90 / 58	25 / 16	41 / 20	14 / 6	31,4 / 27,4
ELEGANCE 120	IPX4	165 / 103	46 / 29	54 / 20	15 / 8	36,7 / 28,4
ELEGANCE 150	IPX4	315 / 182	87 / 50	70 / 15	25 / 13	43,9 / 29,5

*Lp(A) measured at 3m in open field 230V-50Hz.



Comply with ErP Directive 2009/125/CE and EU Regulation 1253/2014 (Classification: Residential Ventilation Unit)

- To exhaust air directly to the outside or into a short length ducting (max 3 m length).
- Suitable for toilets, bathrooms, WC's, shower-rooms, utility rooms and kitchens.
- Innovative design with flat cover and lateral intake.
- Provided with ball bearing motor long Life 30.000 hours and backdraught shutters.
- Advanced profile which optimizes the fluid dynamic performance of the fan.

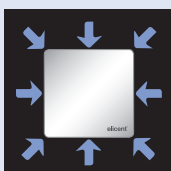

Lateral intake on the whole perimeter

INSTALLATION

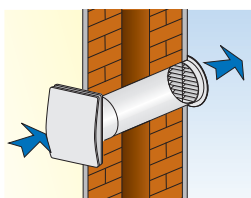

WALL

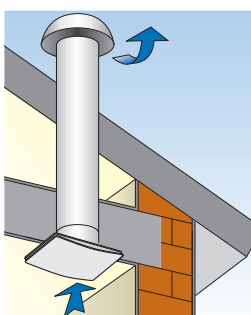

CEILING

VERSIONS

- **STANDARD** - On/off through light or remote control switch
- **PULL CORD** - On/off through pull cord switch
- **TIMER** - Integral electronic timer adjustable from 3 to 25 minutes
- **COMFORTIMER** - Overrun timer at low speed
- **MHY** - Smart Humidity control automatic progressive increase/decrease of fan speed according to the percentage of R.H.
- **2 SPEED** - 24 hours running at the lowest speed
- **2 SPEED MHT** - 2 speed MHT with humidity control

DIMENSIONS (mm)

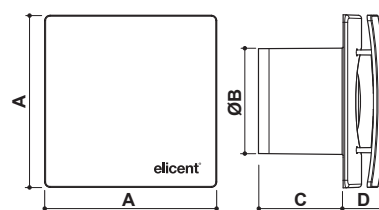

MODELS	A	ØB	C	D	Kg
ELEGANCE 100	160	98	80	38	0,9
ELEGANCE 120	180	119	91	44	1,1
ELEGANCE 150	200	149	105	56	1,3

CURVES

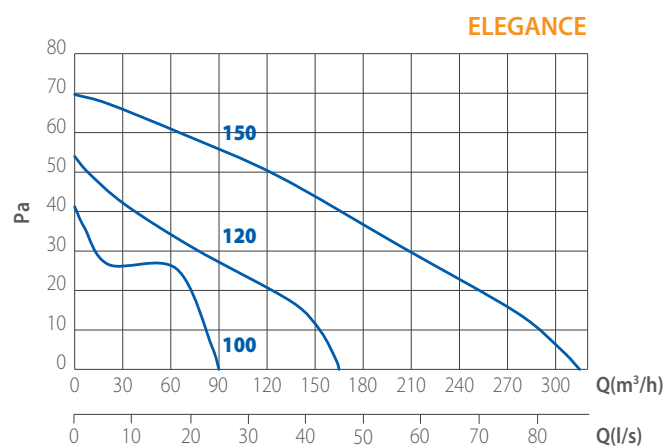



ELEGANCE EC 2V

- Energy efficient EC motor.
- Choice of 2 low speeds at installation.
- Provides low level continuous ventilation to control condensation.
- For any domestic wet room.
- Low noise levels and running costs.
- Wall, ceiling or window (with additional window kit) installation.

GENERAL FEATURES

- Exhausts directly to the outside (through wall, or window installation with additional window kit, or with medium length ducting - up to 6m).
- Runs continuously at pre-selected choice of two speeds (fixed at installation).
- Speed 1 operates at 31 m³/h (9 l/s) (factory set).
- Speed 2 operates at 54 m³/h (15 l/s).
- Anti-vibration gasket.
- Speed boosted to maximum 99 m³/h (27,5 l/s) using integral pull cord or by:
 - Remote switch/light switch
 - Remote PIR sensor
 - Humidistat
- Patented anti-turbulence deflectors ensure very low noise levels and optimum performance.
- Energy saving ventilation.
- Extremely low running costs.
- Low carbon footprint.

TECHNICAL FEATURES

- Shockproof, high quality technopolymer casing.
- Designed using latest wind tunnel technology and CFD simulations.
- EC induction motor with thermal protection.
- 43,000 hour life motors with maintenance free and long life ball bearings.
- Operates in ambient temperatures up to 40°C.
- Double insulated - no earth required.
- IPX4 - Splashproof rated - can safely be installed in Zones I and II.

VERSIONS

EC 2V DT

24 hours running at low speed (selectable between 2 at installation). Speed boosts to maximum via control switch. The maximum speed is provided with a timer (adjustable from 0 to 30 minutes) which activation can be delayed up to 2 minutes to avoid unnecessary night-time operation at the highest speed. (DT option, selectable at installation).

EC 2V HDT

24 hours running at low speed (selectable between 2 at installation). Speed boosts to maximum automatically and/or manually:

- automatically via humidistat (adjustable from 40 to 90% of R.H). The fan switches back to the low speed when the humidity level goes beneath the pre-selected threshold and once concluded the pre-selected overrun via timer (adjustable from 0 to 30 min).

- manually via control switch (remote or pull cord). The fan switches back to the low speed once concluded the pre-selected overrun via timer (adjustable from 0 to 30 min). The activation of the timer can be delayed up to 2 minutes to avoid unnecessary night-time operation at the highest speed. (DT option, selectable at installation).

All EC models (100 2 speed, 2V DT, 2V HDT) are also available in SELV version, low voltage 12V.

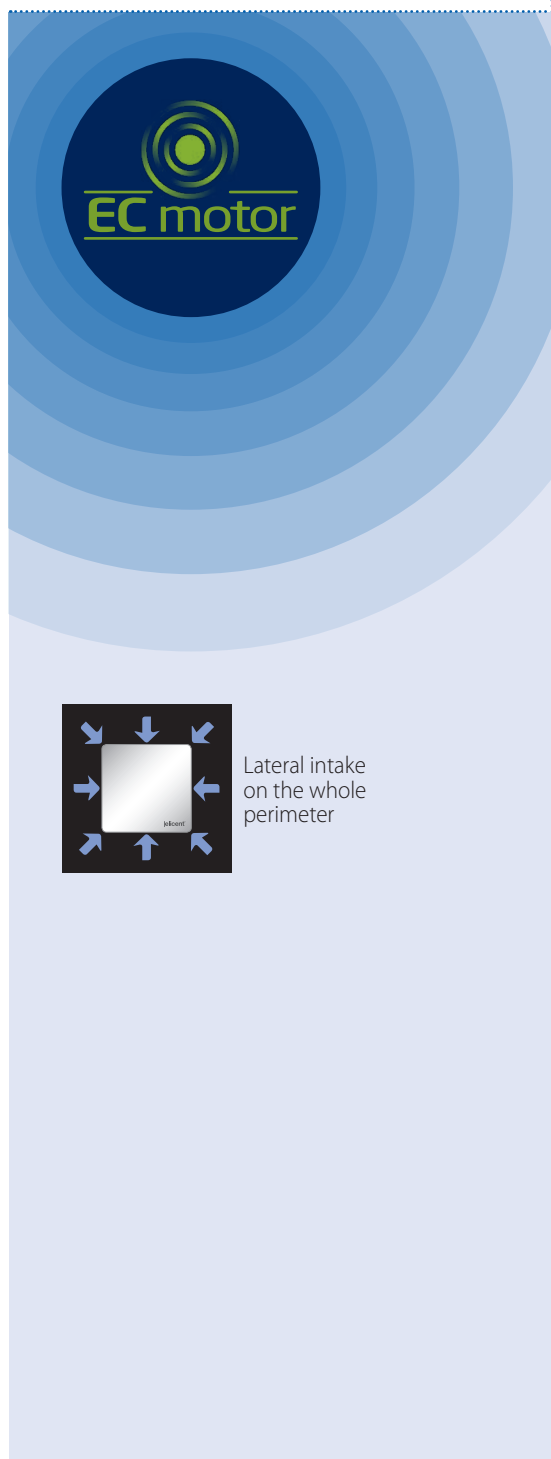

Lateral intake
on the whole
perimeter

PERFORMANCE

MODEL	AIRFLOW m ³ /h - l/s			POWER - Watt			dB(A)		
	Speed 1	Speed 2	max	Speed 1	Speed 2	max	Speed 1	Speed 2	max
ELEGANCE 100 EC 2V	29 / 8	49 / 13,6	97 / 27	0,5	0,8	3,4	15	16	32

*Lp(A) measured at 3m in open field 230V-50Hz.

CURVES

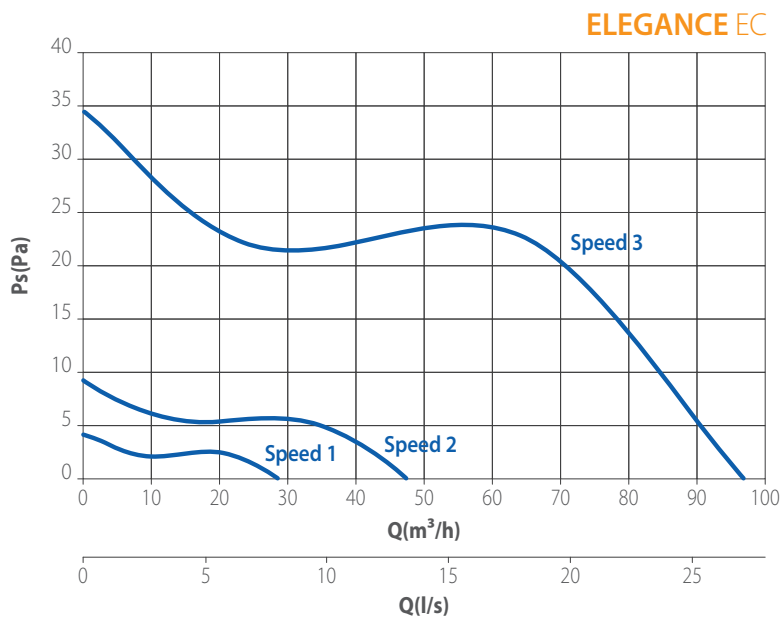

DIMENSIONS (mm)

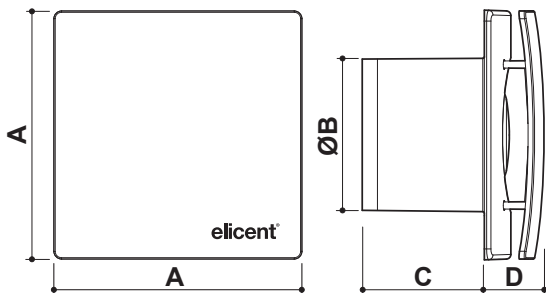

MODEL	A	ØB	C	D	Kg
ELEGANCE 100 EC 2V	160	98	80	38	0,9

INSTALLATION

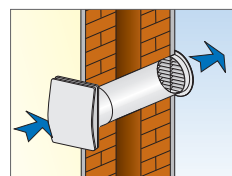

Wall installation

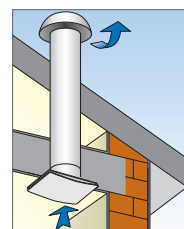

Ceiling installation



PERFORMANCES

MODELS	m ³ /h	l/s	Pa	W	dB (A)*
E-STYLE 90	80	22	23	10	30,1
E-STYLE 100	95	26	42	14	31,4
E-STYLE 120	165	46	55	15	36,7
E-STYLE 150	315	87	71	25	43,9

*Lp(A) measured at 3m in open field 230V-50Hz.

CURVES

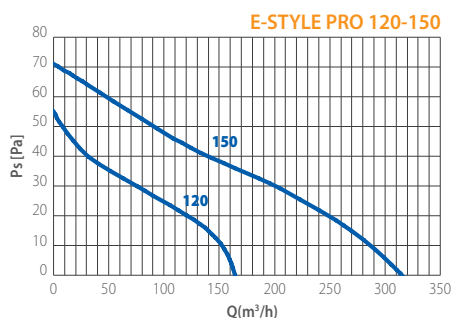
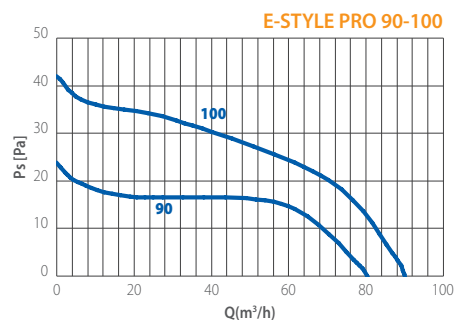

17 mm

ULTRA SLIM



Comply with ErP Directive 2009/125/CE and EU Regulation 1253/2014 (Classification: Residential Ventilation Unit)

- To exhaust air directly to the outside or into a short length ducting (max 3 m length).
- Suitable for toilets, bathrooms, WC's, shower-rooms, utility rooms and kitchens.
- Provided with back draught shutters on models 100, 120, 150
- Neon running light
- Style, technology

INSTALLATION

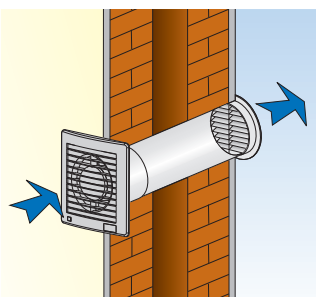

WALL

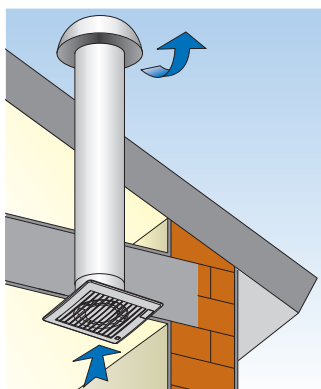

CEILING

VERSIONS

- STANDARD**
On/off through light or remote control switch.
- TIMER**
Integral electronic timer adjustable from 3 to 25 minutes.
- MHT**
Humidity control, adjustable from 40 to 80% of R.H.
- SELV**
SELV 12 V a.c.

DIMENSIONS (mm)

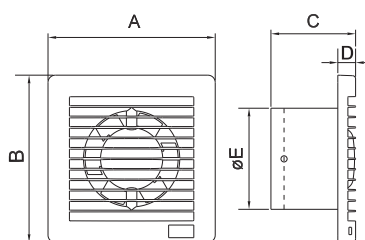

MODELS	A	B	C	D	Eø	Kg
E-STYLE 90	160	160	81	17	92	0,4
E-STYLE 100	160	160	95	17	98	0,4
E-STYLE 120	180	180	101	18	119	0,6
E-STYLE 150	200	200	119	22	149	1,0

ACCESSORY



chrome



inox satin



PERFORMANCES

MODELS	PROTECTION	m ³ /h	l/s	Pa	W	dB(A)*
E-Style 100 TREND	IPX4	85	24	32	11	26,4
E-Style 120 TREND	IPX4	165	46	54	15	36,7
E-Style 150 TREND	IPX4	295	82	71	25	43,9

*Lp(A) measured at 3m in open field 230V-50Hz.

CURVES

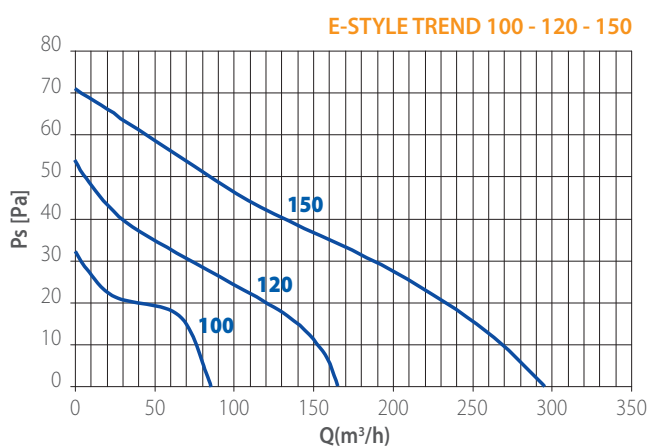

DIMENSIONS

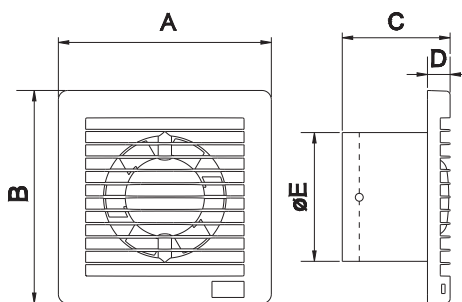

MODELS	A	B	C	D	ØE	Kg
E-Style 100 TREND	160	160	95	17	98,2	0,45
E-Style 120 TREND	180	180	101	18	119	0,66
E-Style 150 TREND	200	200	119	22	149	1,04

17 mm



Comply with ErP Directive 2009/125/CE and EU Regulation 1253/2014 (Classification: Residential Ventilation Unit)

- To exhaust air directly to the outside or into a short length ducting (max 3 m length).
- Suitable for toilets, bathrooms, WC's, shower-rooms, utility rooms and kitchens.
- Basic version of e-style pro (no neon running light - back draught shutters upon request)
- Complete range and high aerualic performances.
- Back draught shutter upon request.

ULTRA SLIM

VERSIONS

- Standard
- Timer
- MHT humidity control



P.I.R. MODEL with passive infrared sensor.

- Available in 3 sizes: Ø100, 120 and 150
- Provided with integral timer, adjustable from 3 to 25 mn
- Ideal for public premises
- Quick and easy installation as it is not necessary to install a control switch
- Completely automatic running



Comply with ErP Directive 2009/125/CE and EU Regulation 1253/2014 (Classification: Residential Ventilation Unit)

INSTALLATION



IDEAL FOR PUBLIC PREMISES

DETECTION SPECTRUM

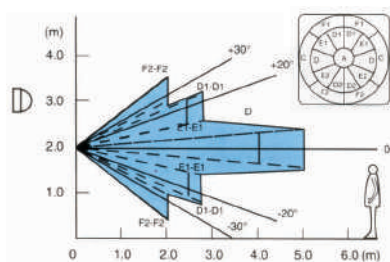
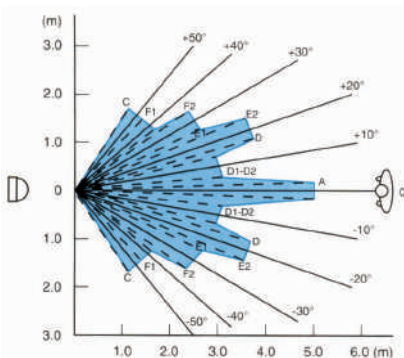

PERFORMANCES

MODELS	m ³ /h	l/s	Pa	W	dB (A)*
E-STYLE 100 P.I.R.	90	25	42	14	31,4
E-STYLE 120 P.I.R.	165	46	55	15	36,7
E-STYLE 150 P.I.R.	315	87	71	25	43,9

* Sound pressure at 3 mt

DIMENSIONS (mm)

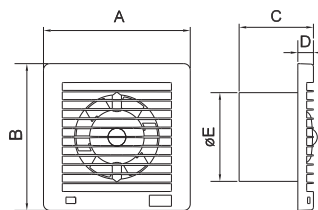

MODEL	A	B	C	D	Eø	Kg
E-STYLE 100 P.I.R.	160	160	95	17	98	0,4
E-STYLE 120 P.I.R.	180	180	101	18	119	0,6
E-STYLE 150 P.I.R.	200	200	119	22	149	1,0

CURVES

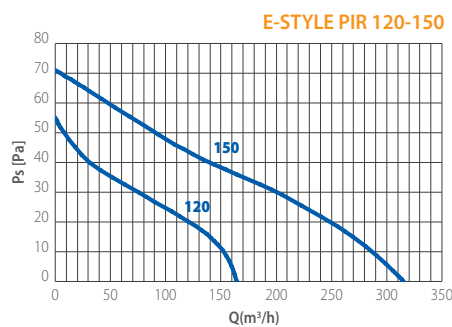
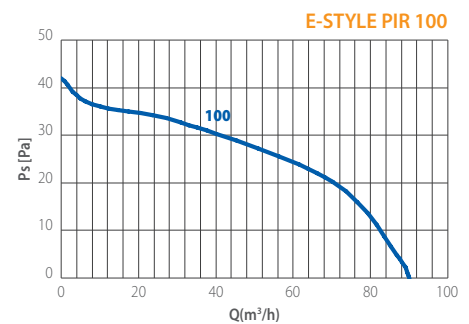



ECO GF
Fixed grille



ECO GG
Gravity shutter



ECO A
Automatic



PERFORMANCES

MODELS	m³/h	Is	Pa	W	dB (A)*
ECO 100	90	25	26	11	39
ECO 120	170	47	39	15	42
ECO 150	320	89	69	25	49

* LpA measured at 3 m in open field 230v - 50Hz.

VERSIONS

- STANDARD**
On/off through light or remote control switch
- PULL CORD**
On/off through pull cord switch
- TIMER**
Integral electronic timer adjustable from 3 to 25 minutes
- MHT**
Humidity control, adjustable from 40 to 80% of R.H.
- 2 SPEED**
24 hours running at the lowest speed
- SELV**
SELV 12 V a.c. (only GG and GF models)



Comply with ErP Directive 2009/125/CE and EU Regulation 1253/2014 (Classification: Residential Ventilation Unit)

- To exhaust air directly to the outside or into a short length ducting (max 3 m length).
- Suitable for toilets, bathrooms, WC's, shower-rooms, utility rooms and kitchens.
- Wide range: 27 models all suitable for wall, window and ceiling installation.
- Low energy consumption and high performance for a quick and efficient extraction of stale air.

INSTALLAZIONI

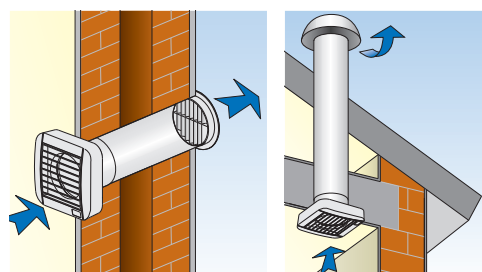

WALL

CEILING

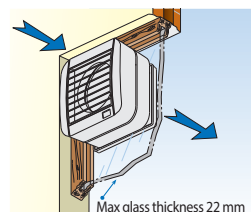

WINDOW
(with window kit)

Max glass thickness 22 mm

DIMENSIONS (mm)

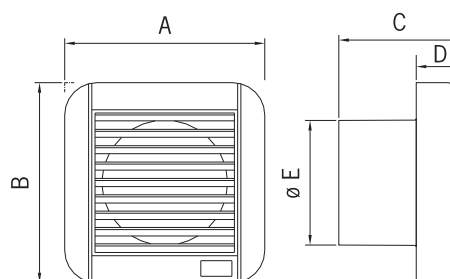

MODELS	A	B	C	D	E	Kg.
ECO 100 GF	155	155	92	35	97	0,5
ECO 120 GF	180	180	121	51	119	0,8
ECO 150 GF	209	209	137	52	149	1,2
ECO 100 GG	155	155	92	35	97	0,5
ECO 120 GG	180	180	121	51	119	0,8
ECO 150 GG	209	209	137	52	149	1,2
ECO 100 A	155	155	101	44	97	0,6
ECO 120 A	180	180	121	51	119	0,8
ECO 150 A	209	209	137	52	149	1,2

CURVES

ECO GF/A 100 / 120 / 150

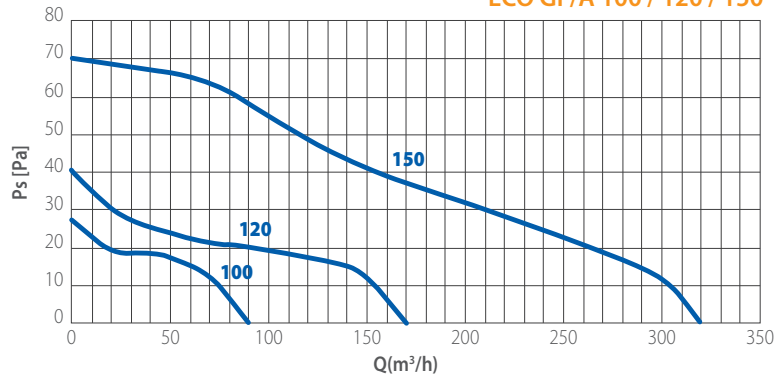

ECO GG 100 / 120 / 150

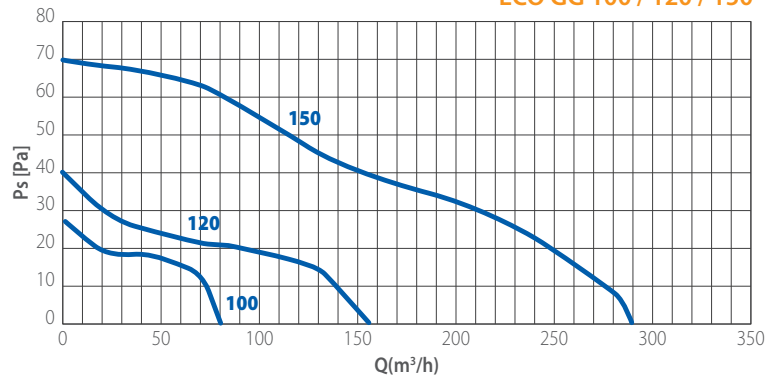

WINDOW KIT



WINDOW KIT GG
(gravity shutter)

Suitable for ECOLINE GF

MODEL
WINDOW KIT GG 100
WINDOW KIT GG 120
WINDOW KIT GG 150



WINDOW KIT GF
(grille fixed)

Suitable for ECOLINE GG and A

MODEL
WINDOW KIT GF 100
WINDOW KIT GF 120
WINDOW KIT GF 150

DIMENSIONS (mm)

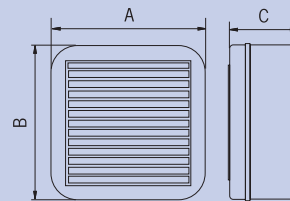

MODEL	A	B	C	Ø glass hole
WINDOW KIT 100	157	157	66	150
WINDOW KIT 120	178	178	82	175
WINDOW KIT 150	208	208	95	175



PERFORMANCES

MODEL	m ³ /h	l/s	Pa	W	dB (A)*
MINISTYLE	90	25	26	14	39
MINISTYLE TIMER	90	25	26	14	39

*Lp(A) measured at 3m in open field 230V-50Hz.



Comply with ErP Directive 2009/125/CE and EU Regulation 1253/2014 (Classification: Residential Ventilation Unit)

- Ideal for small premises
- Easy to install and extremely compact (front cover 17 mm, height and width 14 mm)
- Made in high quality antistatic technopolymer
- Available with back draught shutters on request

INSTALLAZIONI

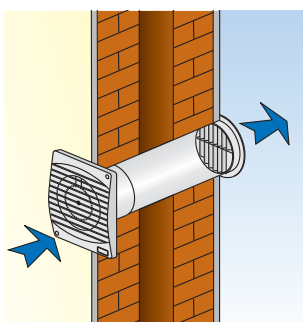

WALL

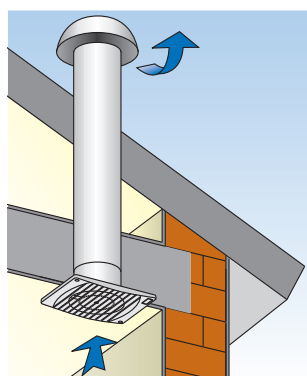

CEILING

CURVE

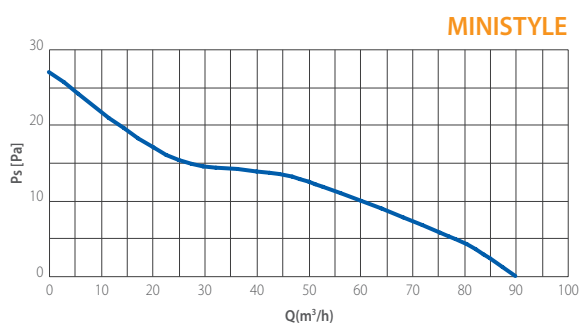

VERSIONS

- STANDARD**
On/off through light or remote control switch.
- PULL CORD**
On/off through pull cord switch.
- TIMER**
Integral electronic timer adjustable from 3 to 25 minutes.

DIMENSIONS (mm)

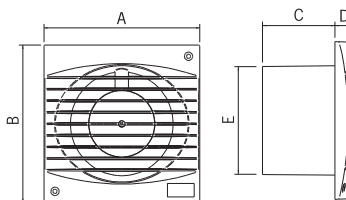

MODEL	A	B	C	D	E	Kg.
MINISTYLE	140	140	65	17	98	0,5



PERFORMANCES

MODELS	m ³ /h	Pa	W	dB(A)	PROTECTION
MURO 100	95	29	11	39	IPX4
MURO 120	180	43	15	42	IPX4
MURO 150	320	70	25	49	IPX4
MURO 100 A	110	35	11	39	IPX4
MURO 100 PIR	95	27	14	39	IPX2

*Lp(A) measured at 3m in open field 230V-50Hz.

CURVES

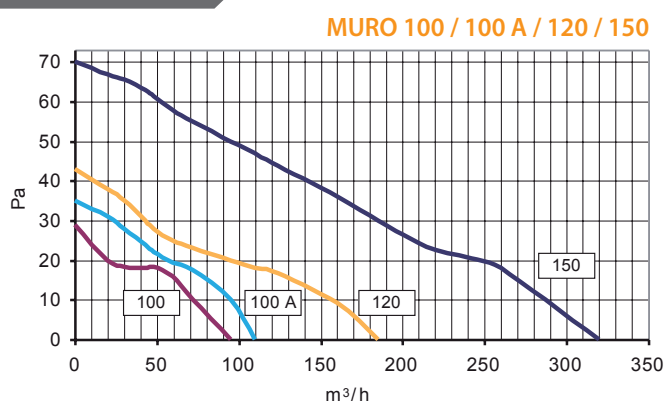

Comply with ErP Directive 2009/125/CE and EU Regulation 1253/2014 (Classification: Residential Ventilation Unit)

- To exhaust air directly to the outside or into a short length ducting (max 3 m length).
- Suitable for toilets, bathrooms, WC's, shower-rooms, utility rooms and kitchens.
- For wall, panel and ceiling installation.
- Available sizes: Ø 100, Ø 120, Ø 150.
- Manufactured in shock-proof high quality technopolymer.
- Maintenance free, self lubricating sleeve bearing motor for long life and noiseless running.
- Induction motor with overheating protection 230V – 50 Hz.
- Easy maintenance and cleaning.
- MURO 100 A with electric opening of the grille.

DIMENSIONS (mm)

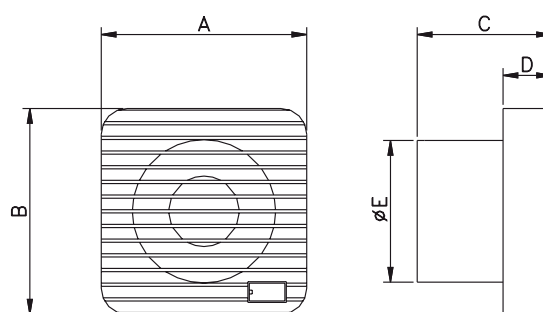

MODEL	A	B	C	D	E	Kg
MURO 100 / 100 PIR	140	140	92	33	97	0,7
MURO 100 A	155	155	91	37	97	0,8
MURO 120	160	160	103	33	119	0,8
MURO 150	180	180	128	33	148	1,2



PERFORMANCES

MODELS	m ³ /h	l/s	Pa	W	dB(A)
JOLLY 100	90	25	18	14	39
JOLLY 120	175	49	35	18	43
JOLLY 150	320	89	71	40	51

*Lp(A) measured at 3m in open field 230V-50Hz.

CURVES

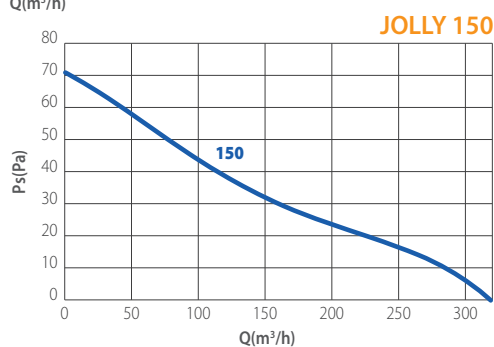
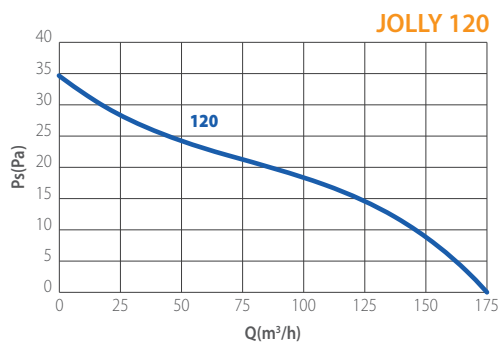
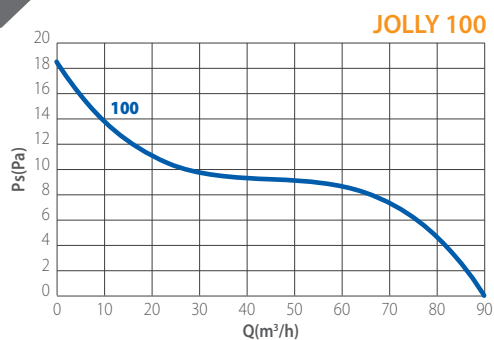

- Wall axial fans suitable for direct exhaust (max duct length 1,5 m).
- Complete range ø 100, 120, 150 mm.
- Compact sizes.
- Manufactured in shock-proof high quality technopolymer.
- Maintenance free, self-lubricating sleeve bearing motor for long life.
- Induction motor with overheating protection 230V - 50/60 Hz.
- Easy installation, maintenance and cleaning.
- Available with back draught shutters upon request.

VERSIONS



Standard version

On/Off via light/remote control switch.



Pull cord switch

On/Off via pull cord switch.



Timer

Integral electronic timer adjustable from 3 to 25 minutes.

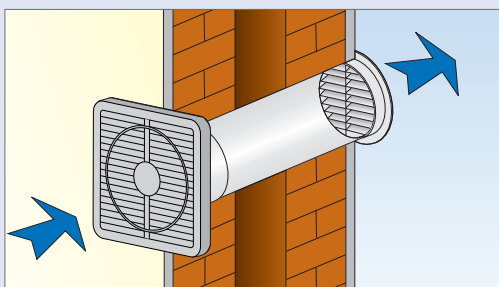

DIMENSIONS (mm)

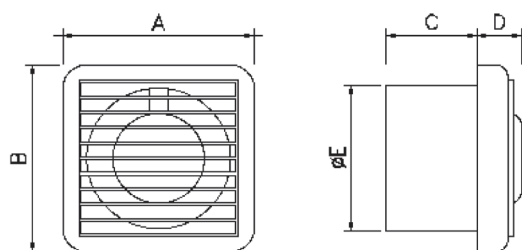

MODEL	A	B	C	D	E
JOLLY 100	125	125	63	29	97
JOLLY 120	150	150	73	29	118
JOLLY 150	185	185	93	29	151

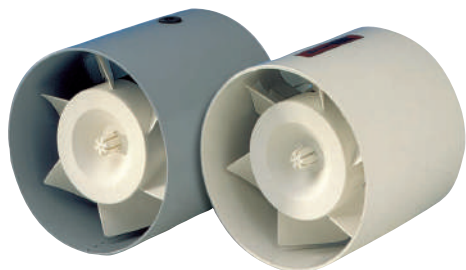

PERFORMANCES

MODELS	m ³ /h	l/s	Pa	W	dB (A)*
TUBO 100	90	25	25	14	38
TUBO 120	180	50	35	18	44
TUBO 150	320	89	69	40	51

*Lp(A) measured at 3m in open field 230V-50Hz.



Comply with ErP Directive 2009/125/CE and EU Regulation 327/2011 (Classification: FAN)

- Suitable for intake / extract ventilation
- Ideal for conveying air between two separate rooms
- Invisible and efficient: no fan into the room
- Metal or Technopolymer versions
- Long Life sleeve bearing motor

CURVES

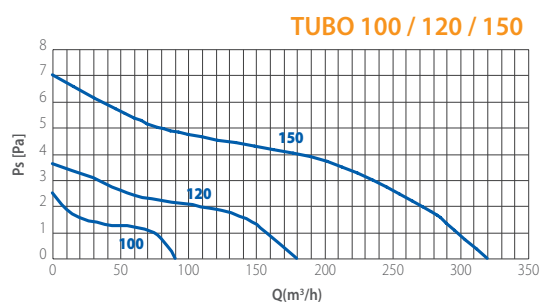

VERSIONS

- STANDARD**
 On/off through light or remote control switch.
- TIMER**
 Integral electronic timer adjustable from 3 to 25 minutes (available on TUBO TP only).

INSTALLATION

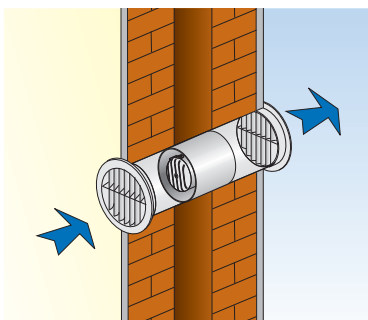

WALL

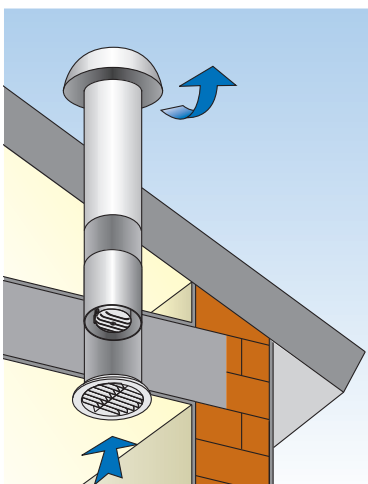

CEILING

DIMENSIONS (mm)

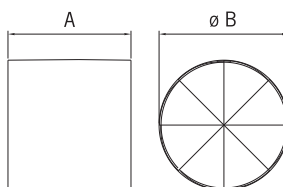

MODELS	A	Ø B	Kg.
TUBO 100	92	97	0,4
TUBO 120	97	119	0,6
TUBO 150	125	151	0,8



BUILT-IN

Built-in wall axial fans



PERFORMANCES

MODELS	m ³ /h	l/s	Pa	W	dB (A)**	Kg
BUILT-IN 9	*740/480	205/133	46 / 35	46	48	11,5
BUILT-IN 12	*1630/850	453/236	75 / 48	106	58	12,5
BUILT-IN 9 LC	*600/374	167/104	42 / 35	29	48	11,5

* Extract / Intake

** Lp(A) measured at 3m in open field 230V-50Hz.



Comply with ErP Directive 2009/125/CE and EU Regulation 327/2011 (Classification: FAN)

- Extract/Intake models available in 2 sizes: 9" and 12" (with same wall hole sizes)
- Built-in 9 available in Low capacity version
- Stylish profile and unobtrusive installation
- High efficiency (up to 1630 m³/h)
- Silent shutter operation via thermal actuator
- Made in shockproof high quality technopolymer
- Sleeve bearing motor

DIMENSIONS (mm)

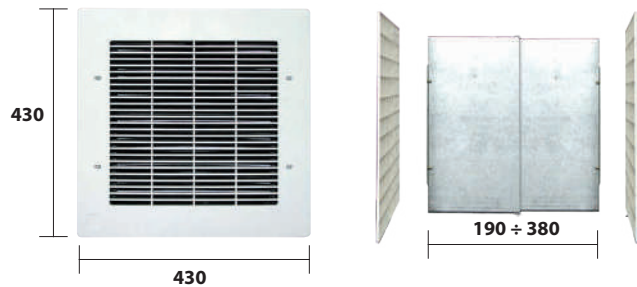

INSTALLATION

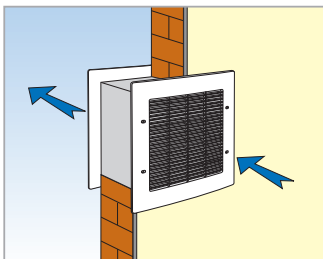

Hole dimensions
(same hole size for 9" and 12")

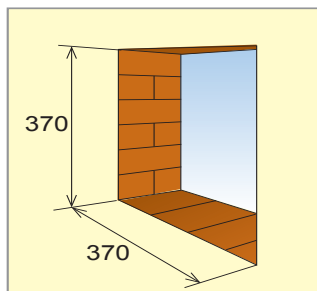



PERFORMANCES

MODELS	PROTECTION	m ³ /h	l/s	W	Pa	dB(A)*
ECOWIND 100 A	IPX4	90	25	13	20	42
ECOWIND 120 A	IPX4	130	36	15	31	44
ECOWIND 150 A	IPX4	260	72	25	60	51

**Lp(A) measured at 3m in open field 230V-50Hz.



Comply with ErP Directive 2009/125/CE and EU Regulation 1253/2014 (Classification: Residential Ventilation Unit)

- Special version of ECO LINE with automatic shutters and provided with assembled kit for window installation.
- To exhaust air directly to the outside or into a short length ducting (max 3 m length).
- Suitable for toilets, bathrooms, WC's, shower-rooms, utility rooms and kitchens.

CURVES

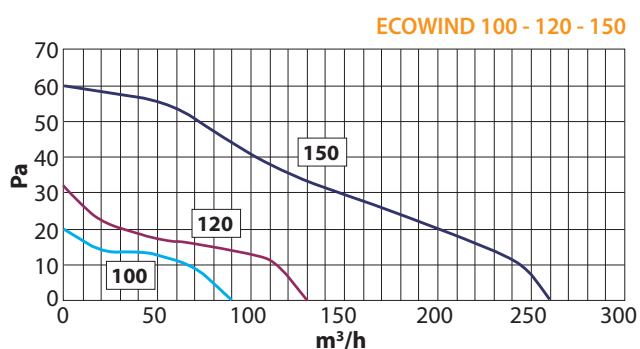

DIMENSIONS

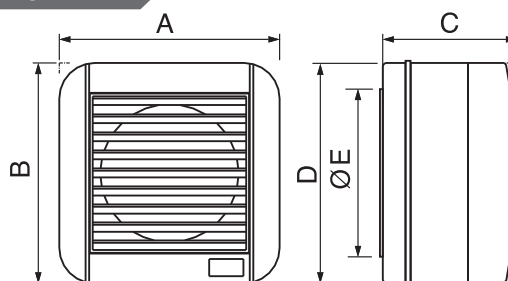

MODELS	A	B	C	D	ØE	Kg
ECOWIND 100 A	155	155	110	157	150	0,8
ECOWIND 120 A	180	180	132	178	175	1,0
ECOWIND 150 A	209	209	147	208	175	1,4



PERFORMANCES

MODELS	m ³ /h	l/s	Pa	W	dB (A)**	MARKED
VITRO 6/150 LC-M	200	56	36	24	40	Ⓜ
VITRO 6/150 LC-A	200	61	36	28	40	Ⓜ
VITRO 6/150 P-M	300	83	74	41	48	Ⓜ
VITRO 6/150 P-A	300	83	74	45	48	Ⓜ
VITRO 9/230 LC-M	600	167	42	29	50	-
VITRO 9/230 LC-AR	*600 / 374	167 / 104	42 / 35	29	50	-
VITRO 9/230 P-M	700	194	52	43	50	Ⓜ
VITRO 9/230 P-AR	*700 / 400	194 / 111	55	46	50	Ⓜ
VITRO 12/300 AR	*1.400 / 800	389 / 222	83	106	59	Ⓜ

* Extract / Intake

** Lp(A) measured at 3m in open field 230V-50Hz.



Comply with ErP Directive 2009/125/CE and EU Regulation 327/2011 (Classification: FAN)

- High extract performance for polluted premises, ideal for commercial environments.
- Suitable for wall, double window and double glazed window installation (accessories upon request).
- 9" and 12" (automatic versions) are suitable for reverse running.
- All IMQ marked except VITRO 9/230 LCM and VITRO 9/230 LC-AR

VERSIONS

- M** **MANUAL** - Pull cord switch.
- A** **AUTOMATIC**
Automatic electrical opening of the shutter. On/Off via light/remote switch.
- AR** **AUTOMATIC REVERSIBLE**
Automatic electrical opening of the shutter. On/Off via light/remote switch. + Reversible air flow through reversible speed controller RS/R, RVS/R or RVS/R
- P** **POTENTIATED**
Potentiated motor for higher airflow performance.
- LC** **LOW CAPACITY**
(LCM - Low capacity Manual / LC-AR Low capacity Automatic Reversible).

CURVES

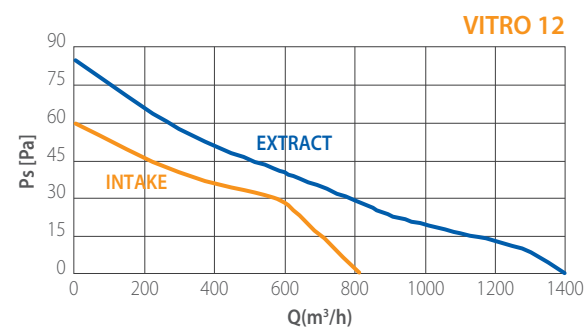
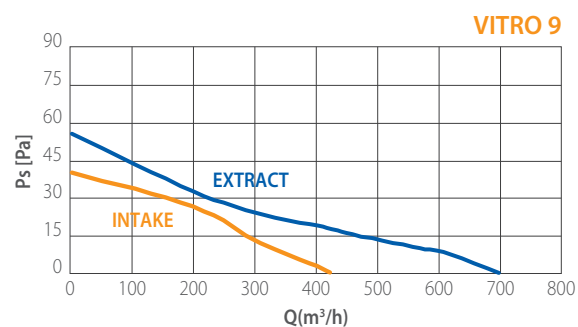
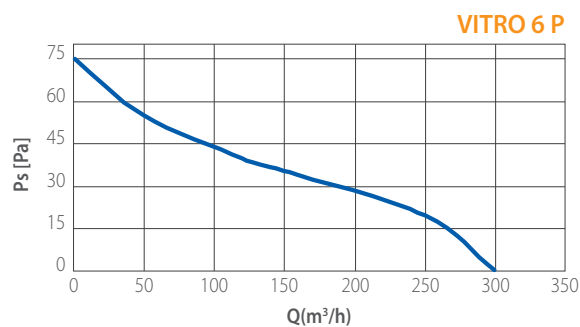
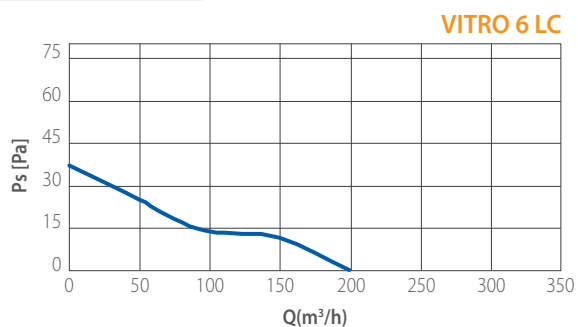

DIMENSIONS (mm)

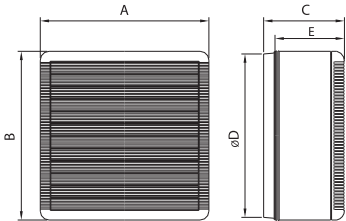

MODELS	A	B	C	Ø D	E	Kg.
VITRO 6/150	195	195	126	184÷188	102	1,7
VITRO 9/230	287	287	138	254÷258	122	3,5
VITRO 12/300	364	364	162	324÷329	137	5



Thermoactuator for the electrical opening of the grille.



Pull cord switch version.

INSTALLATION

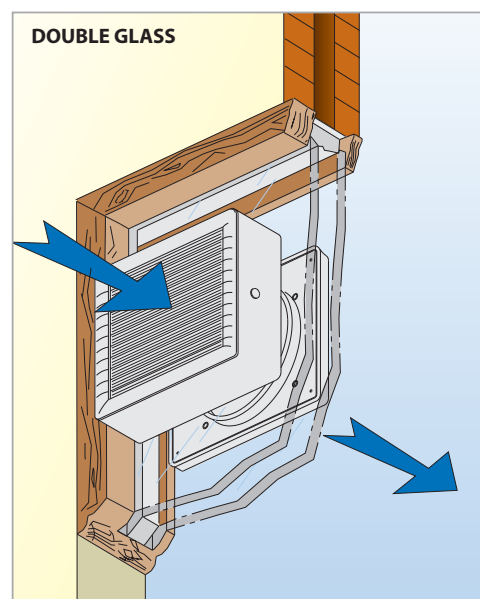
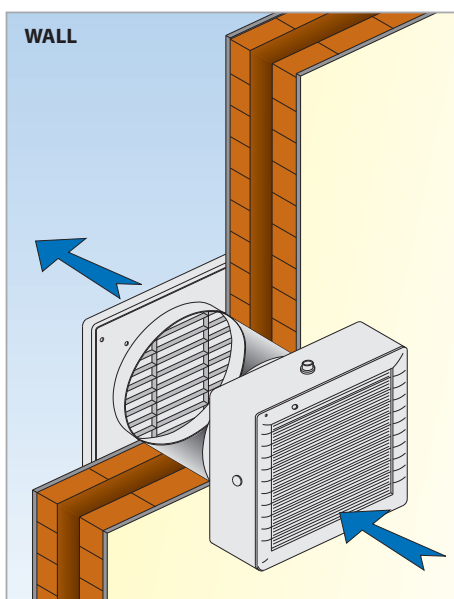
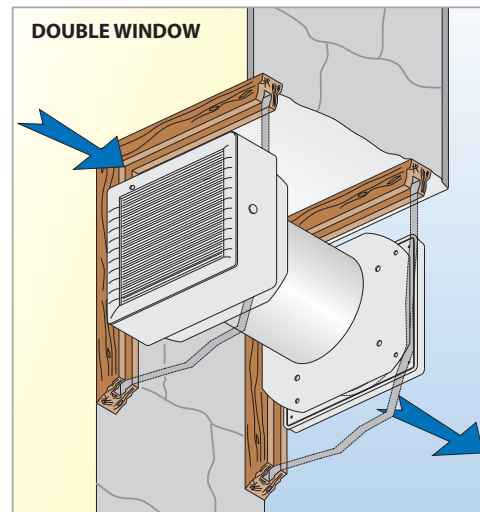
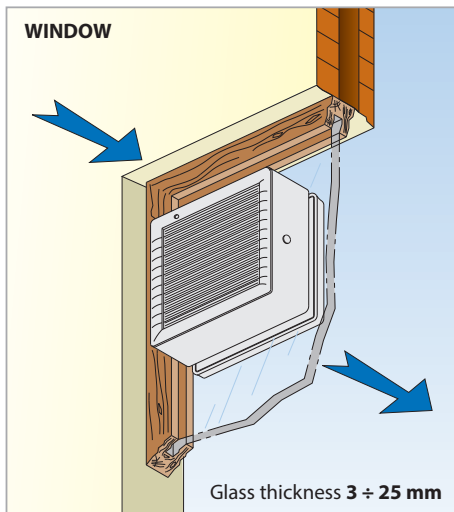



PERFORMANCES

MODELS	Protection	m ³ /h	l/s	dB(A)*	Pa	W
MINIVITRO 4/100 A MFE	IPX4**	90	25	39	19	11
MINIVITRO 4/100 MGE	IPX2-IPX4**	90	25	40	33	14
MINIVITRO 5/120 MGE	IPX2-IPX4**	160	44	43	51	18
MINIVITRO 6/150 MGE	IPX2**	200	56	43	51	27

* At 3 m - 230V/50Hz
A = automatic - MGE = with external gravity shutter - MFE = with external fixed grille.
** External part.



Comply with ErP Directive 2009/125/CE and EU Regulation 327/2011 (Classification: FAN)

- Special version of VITRO suitable for wall or window installation, to exhaust air directly to the outside or into a short length ducting.
- Compact dimensions.
- Model A with automatic shutter and external fixed grille.

DIMENSIONS (mm)

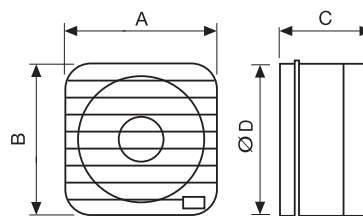

MODEL	A	B	C	ØD
MINIVITRO 4/100 A MFE	155	155	99	152
MINIVITRO 4/100 MGE	155	155	99	152
MINIVITRO 5/120 MGE	160	160	109	152
MINIVITRO 6/150 MGE	180	180	112	176



PERFORMANCES

MODEL	DUCT Ø	m³/h	l/s	Pa	W	dB(A)*
Standard - Pull cord - Timer - MHY smart - SELV						
ELIX 100	100	97	27	151	29	42
Comfortimer - 2 speed						
ELIX 100	100	97 / 54	27 / 15	151 / 116	29 / 14	42 / 23

* Lp(A) measured at 3m in open field 230V-50Hz.



Comply with ErP Directive 2009/125/CE and EU Regulation 1253/2014 (Classification: Residential Ventilation Unit)

- Centrifugal duct fan Ø 100 mm with central outlet.
- Innovative design with flat front cover and lateral intake.
- Available with EC motor for a perfect combination of style and performance.
- Provided with sliding filter in PP removable and washable in dishwasher and with back-draught shutters.

INSTALLATION

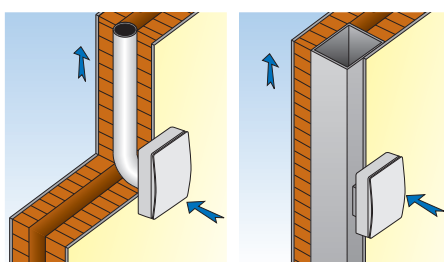

Multiple Duct

Single Duct



Antivibration gasket

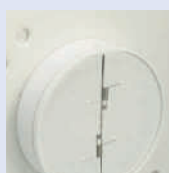

Central outlet

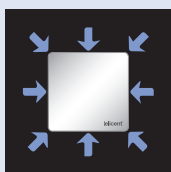

Lateral intake on the whole perimeter



Sliding filter

CURVES

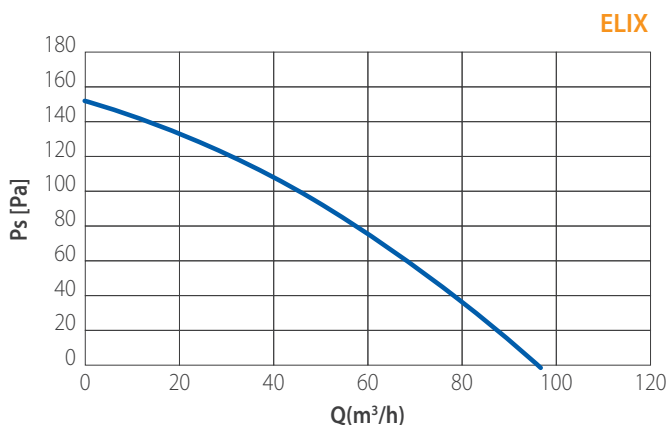

DIMENSIONS (mm)

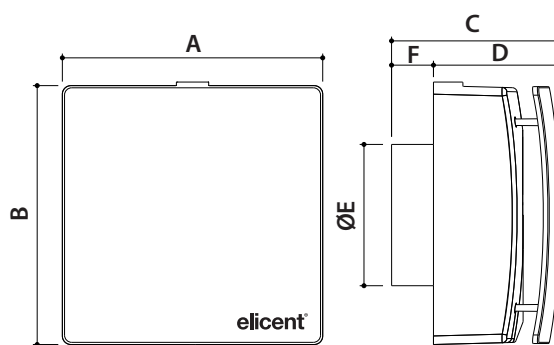

MODEL	A	B	C	D	E	F	Kg
ELIX 100	180	180	116	87	99	29	2,6

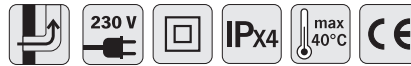

ELIX EC 2V

- Energy efficient EC motor
- Provides low level continuous ventilation to control condensation
- Choice of 2 low speeds at installation
- For wall or ceiling installation
- For any domestic wet room
- Low noise levels and running costs

GENERAL FEATURES

- Exhausts directly to the outside or through long lengths of ducting (up to 15m).
- Runs continuously at pre-selected choice of two speeds (fixed at installation).
- Speed 1 operates at 29 m³/h (8 l/s) (factory set).
- Speed 2 operates at 50 m³/h (14 l/s).
- Max speed boosted to maximum 100 m³/h (28 l/s) using integral pull cord or by:
 - Remote switch/light switch
 - Remote PIR sensor
 - Humidistat
- Anti-vibration gasket.
- Easily removable, washable polypropylene filter.
- Energy saving ventilation.
- Extremely low running costs.
- Low carbon footprint.

TECHNICAL FEATURES

- Shockproof, high quality technopolymer casing.
- Designed using latest wind tunnel technology and CFD simulations.
- Profile increases the fluid dynamics.
- EC induction motor with thermal protection.
- 43,000 hour life motors with maintenance free and long life ball bearings.
- Operates in ambient temperatures up to 40°C.
- Double insulated - no earth required.
- IPX4 - Splashproof rated - can safely be installed in Zones I and II.

VERSIONS

EC 2V DT

24 hours running at low speed (selectable between 2 at installation). Speed boosts to maximum via control switch. The maximum speed is provided with a timer (adjustable from 0 to 30 minutes) which activation can be delayed up to 2 minutes to avoid unnecessary night-time operation at the highest speed. (DT option, selectable at installation).

EC 2V HDT

24 hours running at low speed (selectable between 2 at installation). Speed boosts to maximum automatically or manually:

- automatically via humidistat (adjustable from 40 to 90% of R.H). The fan switches back to the low speed when the humidity level goes beneath the pre-selected threshold and once concluded the pre-selected overrun via timer (adjustable from 0 to 30 min).
- manually via control switch (remote or pull cord). The fan switches back to the low speed once concluded the pre-selected overrun via timer (adjustable from 0 to 30 min). The activation of the timer can be delayed up to 2 minutes to avoid unnecessary night-time operation at the highest speed. (DT option, selectable at installation).

All EC models (100 2 speed, 2V DT, 2V HDT) are also available in SELV version, low voltage 12V.

- Centrifugal power
- Ø100 mm with central outlet

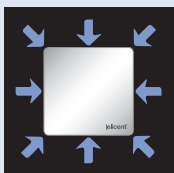

Lateral intake on the whole perimeter



Sliding filter



Antivibration gasket

PERFORMANCE

MODEL	AIRFLOW m ³ /h - l/s			PRESSURE - Pa			POWER - Watt			dB(A)*		
	Speed 1	Speed 2	max	Speed 1	Speed 2	max	Speed 1	Speed 2	max	Speed 1	Speed 2	max
ELIX 100 EC 2V	32 / 9	46 / 13	100 / 28	23	44	200	1,6	2,4	15	16	18	37

* Lp(A) measured at 3m in open field 230V-50Hz.

CURVES

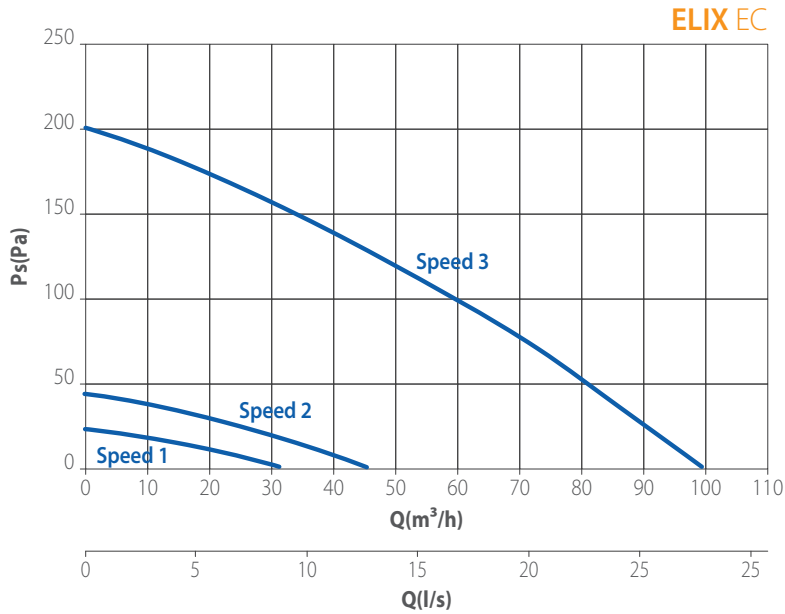

DIMENSIONS (mm)

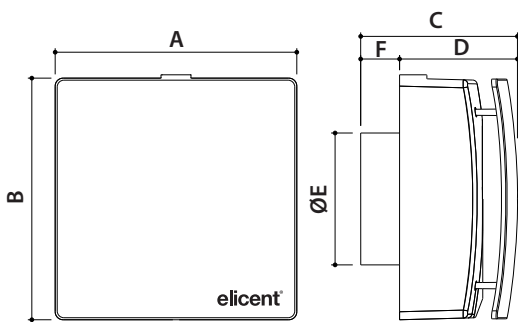

MODEL	A	B	C	D	E	F	Kg
ELIX 100 EC 2V	180	180	116	87	99	29	2,6

INSTALLATION

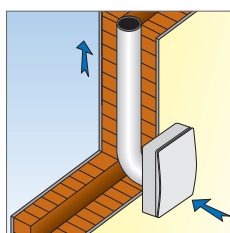

Single duct

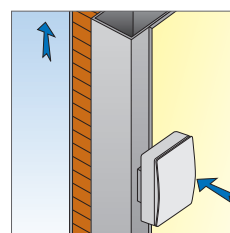

Multiple duct



PERFORMANCES

MODEL	DUCT Ø	m ³ /h	l/s	Pa	W	dB (A)*
STANDARD / PULL CORD / TIMER / MHT						
ELPREX 100	100	221	61	208	29	41
COMFORTIMER / 2 SPEED / HT 2 SPEED						
ELPREX 100	100	221	61	15,82 / 11,10	38,8 / 8,20	41 / 15,80

* Lp(A) measured at 3m in open field 230V-50Hz.



Comply with ErP Directive 2009/125/CE and EU Regulation 1253/2014 (Classification: Residential Ventilation Unit)

- Powerful centrifugal duct fan \varnothing 100 mm with decentralised outlet.
- Innovative design with flat front cover and lateral intake. Suitable for surface or built-in installation (wall/ceiling mounted).
- Casing for built-in installation on request
- Provided with removable filter in PP washable in dishwasher and with back-draught shutters.

CURVES

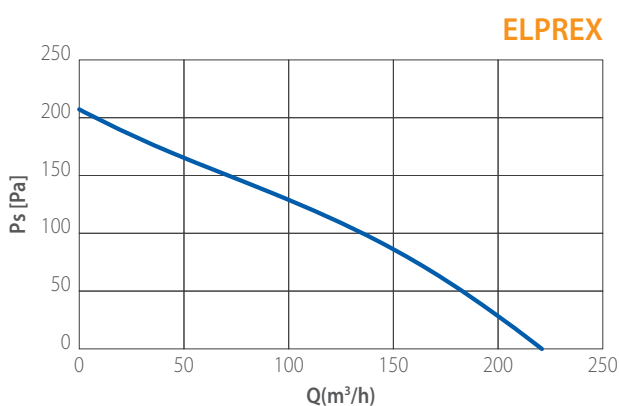

VERSIONS

- STANDARD**
on/off through light or remote control switch.
- PULL CORD**
on/off through pull cord switch.
- TIMER**
integral electronic timer adjustable from 3 to 25 minutes.
- COMFORTIMER**
overrun timer at low speed.
- MHT**
Humidity control, adjustable from 40 to 80% of R.H.
- 2 SPEED**
24 hours running at the lowest speed.



Decentral outlet



Built-in kit

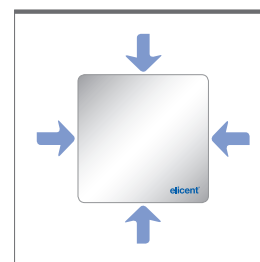

Lateral intake

DIMENSIONS (mm)

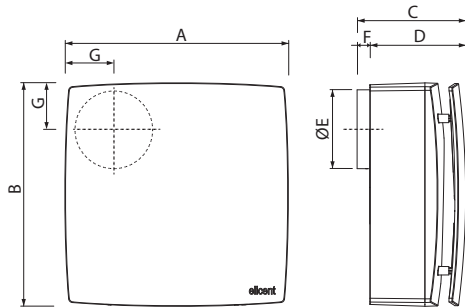

TYPE	A	B	C	D	ØE	F	G	Kg
ELPREX	280	280	135	120	99	16	58	2,8

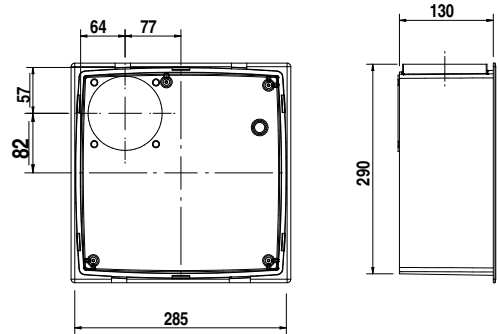

Casing for built-in installation
(to be ordered separately)
2SV0110

INSTALLATION

SURFACE

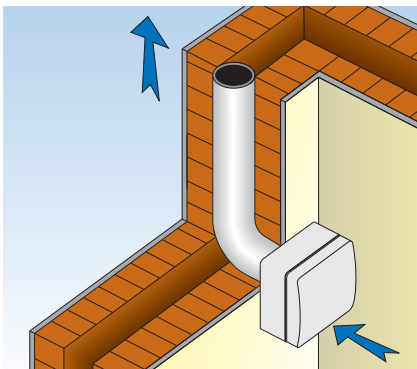

SINGLE DUCT

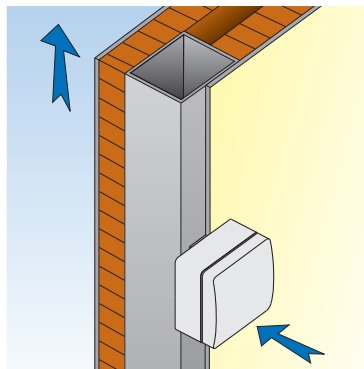

MULTIPLE DUCT

BUILT-IN

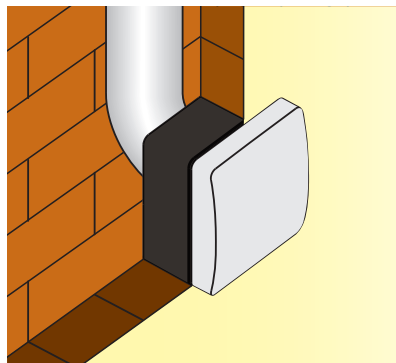
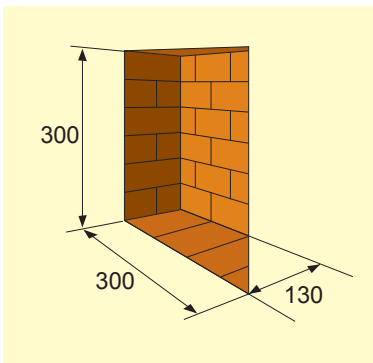

REAR OUTLET

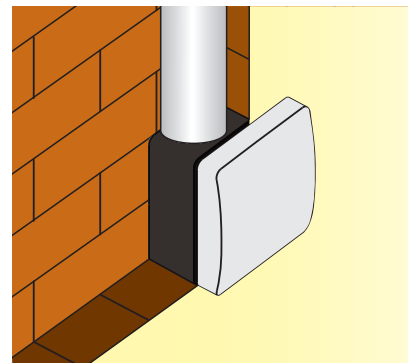

VERTICAL OUTLET



FLUX

Centrifugal duct fans with axial flow discharge



PERFORMANCES

MODELS	DUCT Ø	m³/h	l/s	Pa	W	dB (A)*
Standard - Timer - HT						
FLUX 100	100	90	25	124	30	44
2V - HT 2V						
FLUX 100 2V	100	90 / 38	25 / 10	124 / 78	30 / 12	44 / 37
Selv - Selv Timer						
FLUX 100 SELV	100	90	25	124	26	44
Standard - Timer - HT						
FLUX 250 / Ø 100	100	201	56	195	29	52
FLUX 250 / Ø 120	120	232	64	195	29	52

* Lp(A) measured at 3m in open field 230V-50Hz.



Comply with ErP Directive 2009/125/CE and EU Regulation 1253/2014 (Classification: Residential Ventilation Unit)

- Centrifugal duct fans with central outlet
- 2 models: 100 and 250, Ø 100 and 120 mm
- IMQ mark on Flux 100 (all versions)

VERSIONS

- STANDARD** - On/off through light or remote control switch.
- PULL CORD** - On/off through pull cord switch.
- TIMER** - Integral electronic timer adjustable from 3 to 25 minutes.
- MHT** - Humidity control, adjustable from 40 to 80% of R.H.
- 2 SPEED** - 24 hours running at the lowest speed.

CURVES

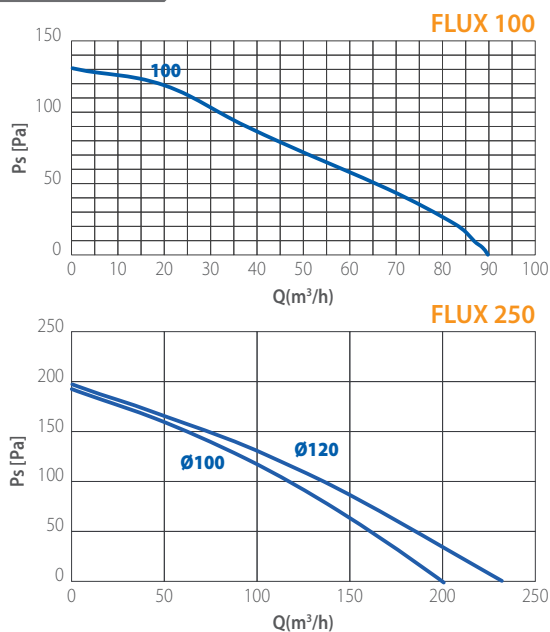

Antivibration gasket



Backdraught shutter



Central outlet

INSTALLATION

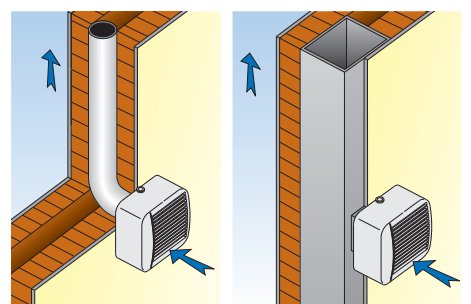

SINGLE DUCT

MULTIPLE DUCT

DIMENSIONS (mm)

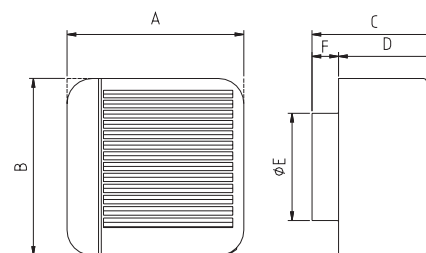

MODELS	A	B	C	D	ØE	F	Kg.
FLUX 100	160	160	119	89	97	30	0,8
FLUX 250/100	210	210	156	131	97	25	1,8
FLUX 250/120	210	210	156	131	119	25	1,8



PERFORMANCES

MODELS	DUCT Ø	m³/h	l/s	Pa	W	dB (A)*
RADIA 80	80/100	80	22	108	23	39
RADIA 130	100	130	36	177	29	44
RADIA 220	100	220	61	277	29	50

* Lp(A) measured at 3m in open field 230V-50Hz.

CURVES

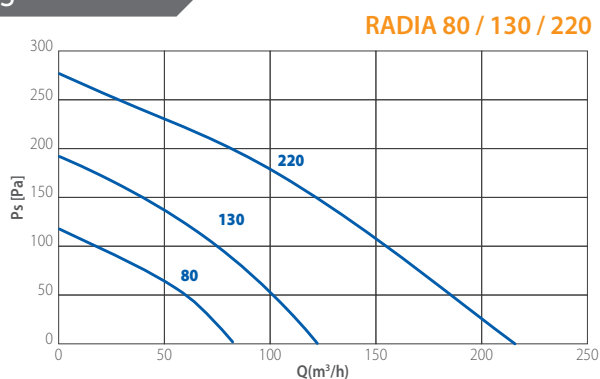

Comply with ErP Directive 2009/125/CE and EU Regulation 1253/2014 (Classification: Residential Ventilation Unit)

- Classical centrifugal fans designed to overcome the pressure and resistance caused by long lengths of ducting.
- Provided with back draught shutter and removable filter.
- IMQ mark on RADIA 80 and 130.
- On Request, 2V and 2V HT versions.

INSTALLATION

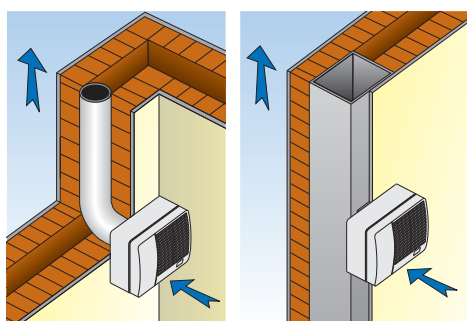

1 - SINGLE DUCT

2 - MULTIPLE DUCT



Decentral outlet



Backdraught shutter

VERSIONS

- STANDARD**
On/off through light or remote control switch.
- PULL CORD**
On/off through pull cord switch.
- TIMER**
Integral electronic timer adjustable from 3 to 25 minutes.
- MHT (Radia 80 - 130 only)**
Humidity control, adjustable from 40 to 80% of R.H.
- 2 SPEED (Radia 80 - 130 only)**
24 hours running at the lowest speed.
- MHT - 2V (Radia 80 - 130 only)**
Humidity control, adjustable from 40 to 80% of R.H.

DIMENSIONS (mm)

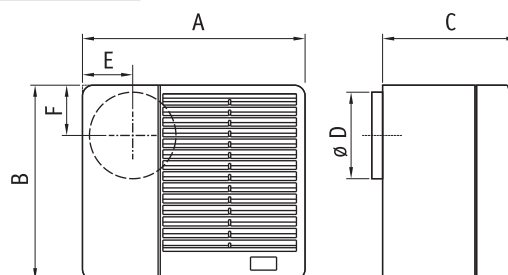

MODELS	A	B	C	Ø D	E	F	Kg.
* RADIA 80	206	180	135	80	48	47	1,2
RADIA 130	237	211	146	98	57	56	1,8
RADIA 220	304	256	171	98	56	61	3

* Supplied with adaptor for ducts Ø100 mm



TIRAFUMO

Roof radial extract fans for fireplaces

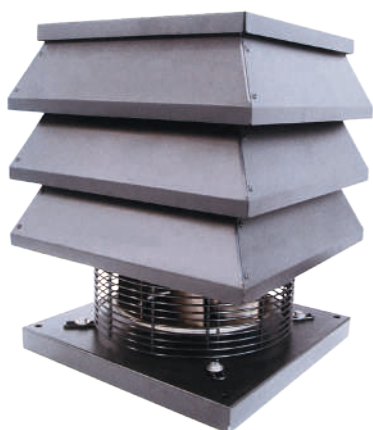

PERFORMANCES

MODEL	m ³ /h	l/s	Pa	W	A	dB (A) *
TIRAFUMO	850	236	190	97	0,9	52,5

* Lp(A) measured at 3m in open field 230V-50Hz.

VERSIONS

TIRAFUMO - N

Steel

TIRAFUMO - NC

Copper



The series is not affected by the ErP Directive 2009/125/CE and further Regulations.

- Ideal for improving the draught of residential fireplaces
- Suitable for chimneys with a section of max 150 x 150 mm (equivalent \varnothing 170 mm) and air temperature of max. 200°C in continuous running
- Easy installation (just Plug & Play)
- Made in steel or copper with highly resistant epoxy finish

INSTALLATION



SUPPLIED



Counterbase to wall up



Plug-in junction box



Eyebolts



Electronic speed controller **R15**

DIMENSIONS (mm)

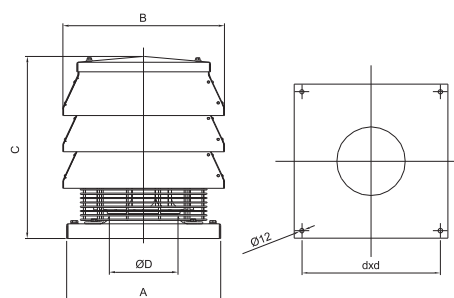

MODEL	A	B	C	Ø D	d	Kg.
TIRAFUMO	400	420	540	178	360	22

CURVE

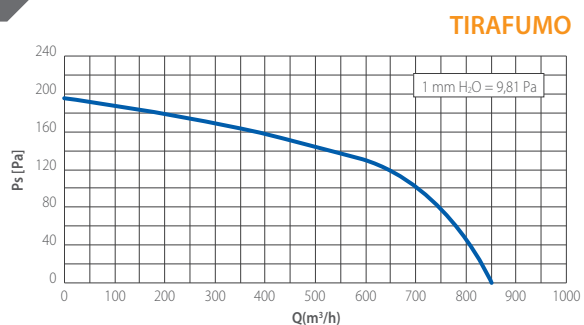

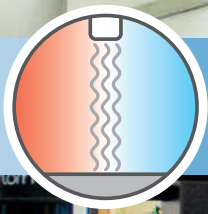

AIR CURTAINS



PRINCIPLE

In buildings where the **entrance doors are continuously opened and closed it is useful to block the inflow of undesired outdoor air** during the winter period and to protect indoor spaces from warm air entering during the summer period. In fact, due to the temperature difference that is generated, **there is a progressive loss of power in the temperature control system**, as well as notable humidity imbalances and discomfort for the public, which reduces their time spent in the establishment.

Furthermore, in commercial places with a high customer inflow and rotation, **the presence of traditional entrance doors may constitute a psychological barrier for the customers**, which operators obviously wish to avoid (such as department stores, supermarkets, bars, restaurants, boutiques).

BENEFITS

To obtain a notable energy saving, keeping warm or cool air inside commercial and non-commercial premises, and contribute to making the indoor air healthier by not allowing smog, unpleasant odours, dust, pollen and insects to enter, air curtains come into play.

Air curtains are devices that enable the formation of an invisible vertical wall of air between the indoor area of premises (generally heated or air conditioned) and outdoors, without limiting access by people or vehicles. Depending on the season, the air is mixed in different temperatures and at different supply speeds, in order to reach the optimal conditions for people to pass through.

For this reason they are particularly suited to being used in commercial locations, such as department stores, bars and shops, located either inside or outside of shopping centres, and in places where time that the doors are open is particularly significant for the indoor air conditioning systems (receptions, warehouses, gyms).

The protection offered to the environment enables customers to enter and exit at will, without impeding their path and also maximising visibility of the environment while increasing indoor comfort.

Maico Italia - Elicent® air curtains:

- ✓ ELDOOR TZ - Tangential
- ✓ ELDOOR CF - Centrifugal

are the most innovative and easy to install product on the market to create situations of safe wellbeing and energy saving, drastically reducing energy consumption for heating and cooling, while also protecting the quality of the indoor air.

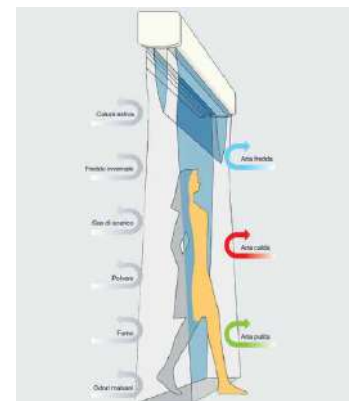



ELDOOR TZ

Tangential air curtains



FEATURES

- 3 sizes: 90, 120 or 150 cm width
- Air velocity 11 m/s
- Installation height: 2,3÷3 m
- 2 speeds (with LED signal)
- Remote controller included
- Single-phase power supply
- Stainless steel and varnished metal housing
- Airflow orientation through deflectors
- Can be coupled with the door magnetic contact (supplied as accessory) for automatic on/off running
- High efficiency and silent running
- Easy to install thanks to the fixing bracket (included)
- Inlet front side allows an installation close to the ceiling
- Supplied with connexion cable and plug (TYPE L, 3 poles, 10A)

INCLUDED

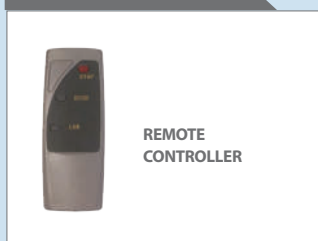

REMOTE CONTROLLER

PERFORMANCE

CODE	UNIT OF MEASUREMENT	MODELS		
		ELDOOR 900 TZ 4BA0000	ELDOOR 1200 TZ 4BA0001	ELDOOR 1500 TZ 4BA0002
Voltage - Frequency	V - Hz	230-50	230-50	230-50
Size (Width)	cm	90	120	150
Impeller diameter	mm	120	120	120
Installation height	m	2.3 - 3	2.3 - 3	2.3 - 3
Electric power	W	150	180	220
Air velocity	m/s	11	11	11
Airflow	m ³ /h	1200	1700	2100
Sound levels	db(A)	45	47	47
Dimensions (L x h x w)	mm	900x220x195	1200x220x195	1500x220x195
Weight	kg	13	16	20



ELDOOR CF

Centrifugal air curtains



FEATURES

- 3 sizes: 90, 120 or 150 cm width
- Air velocity 14,5 m/s
- Installation height: 3÷3,5 m
- 2 speeds (with LED signal)
- Remote controller included
- Single-phase power supply
- Stainless steel and varnished metal housing
- Airflow orientation through deflectors
- Can be coupled with the door magnetic contact for automatic on/off running (supplied as accessory)
- High efficiency and silent running
- Easy to install thanks to the fixing bracket (included)
- Inlet front side allows an installation close to the ceiling
- Supplied with connexion cable and plug (TYPE L, 3 poles, 10A)

INCLUDED

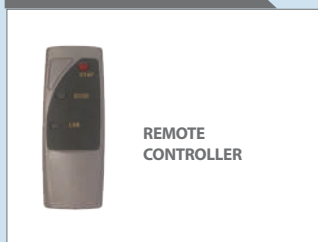

REMOTE CONTROLLER

PERFORMANCE

CODE	UNIT OF MEASUREMENT	MODELS		
		ELDOOR 900 CF 4BA0010	ELDOOR 1200 CF 4BA0011	ELDOOR 1500 CF 4BA0012
Voltage - Frequency	V - Hz	230-50	230-50	230-50
Size (Width)	cm	90	120	150
Impeller diameter	mm	120	120	120
Installation height	m	3.0 - 3.5	3.0 - 3.5	3.0 - 3.5
Electric power	W	220	275	330
Air velocity	m/s	14.5	14.5	14.5
Airflow	m ³ /h	1020	1360	1700
Sound levels	db(A)	44	45	48
Dimensions (L x h x w)	mm	960x230x212	1200x230x212	1500x230x212
Weight	kg	16	19	24



HEATING

Complete range of safe and easy to use electric heaters designed to suit any domestic and industrial requirements, as main or subsidiary heating system.

HOW TO DETERMINE THE NECESSARY ELECTRIC POWER NEEDED FOR ROOMS' HEATING (at a temperature of 22°C)

- 1 Find the volume of the room and multiply it by the value reported on the following graph

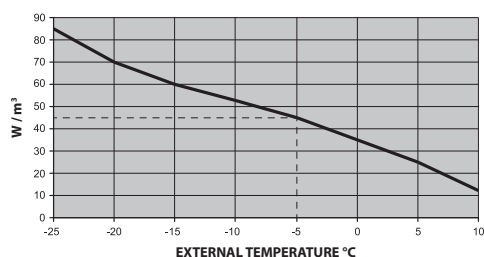

Example: Room's dimensions 5 x 4 x 3 m = 60 m³
External temperature -5°C
Necessary electric power: 45 w/m³ x 60 m³ = 2.700 W

- 2 The result is indicative as it does not take into consideration the insulation and the position of the room;
- 3 For fan heaters, always choose a model with a superior power
- 4 The final temperature regulation has to be made with the ambient thermostat, supplied with each fan
- 5 In case of discontinuous functioning, prefer the choice of fan assisted heater (TCV).

PRINCIPLE

Temperature is one of the main factors that determine man's wellbeing in confined spaces. However, there are situations in which a permanent heating system is not provided or required, both due to the type and the frequency of use of the room. In these cases, it is essential to guarantee people's thermal comfort with versatile heating systems that can be used in any location and/or at any time, whether residential or industrial.

BENEFITS

Electrical heating meets this requirement and also **has the important advantage of not resulting in gas emissions**, in particular carbon dioxide. It is technically simpler than gas heating and easily lends itself to being **managed automatically and the commissioning costs for electrical heating are considerably lower.**

From the point of view of the urban environment, for safety, versatility and comfort there is nothing better than warming yourself up with electricity: no fumes, no risk of explosions or toxic gases, no maintenance, very quick installation, highly responsive and the possibility to adjust the heating with precision over time and space:

✓ **The industrial convection heaters of the VOLCANO R and PRO Series and residential convection heaters of the CALDO Series from Maico Italia - Elicent® create heat quickly and do not require particular maintenance. They offer ease of transport and can be adjusted/programmed.**

✓ **The infrared lamps of the CALDO Series from Maico Italia - Elicent® transmit heat uniformly into the surrounding environment, keeping the relative humidity constant in all of the environment, thereby promoting thermal wellbeing; all of this in just a few moments, without noise, and obviously with light radiation.** In this way it is possible to obtain more pleasant heating at a relatively low environmental temperature, with energy savings too.

COMMERCIAL / INDUSTRIAL

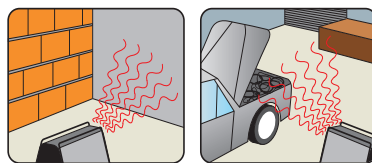

RESIDENTIAL





CALDO 500

Residential



FEATURES

- Antifreeze heater for wall installation
- Adjustable ambient thermostat
- Double insulation
- Provided with Schuko plug
- Armored resistance



CALDO BAGNO 2000

Residential



FEATURES

- Compact and oscillation heater 24h programmable (with intervals of 30 minutes)
- 4 position switch: Off / cold air / Hot air 1000W / Very hot air 2000W
- Adjustable ambient thermostat
- Body in self-extinguishing plastic material
- Double insulation
- Protection IP21
- Heated area: 20 m²





CALDO LAMP 1500 GOLD

Residential



FEATURES

- Radiant heater for outdoor and indoor installation
- Halogen golden resistance of 1500W
- Body in aluminium
- 0/1 pull cord switch
- Provided with wall fixing kit
- IP55 protection heated area: 15 m²



CALDO LAMP 1500

Residential



FEATURES

- Radiant heater for outdoor and indoor installation
- 3 quartz heaters of 1500W (500+500+500)
- Pull cord selection switch
- Wall fixing bracket offering 4 orientations
- Body in steel sheet, front cover in silver paint
- IP24 protection
- Heated area: 18 m²





CALDO TURBO 2000 TECH

Residential



Remote controller included

FEATURES

- Convector heater using natural convection
- Electronic control and remote controller to manage the stand-by function and the ventilation level (3 settings: Eco 750W / Comfort 1250 W / Rapid 2000W)
- Antifreeze function
- Temperature regulation: 5~37°C
- Programmable timer up to 15 hours
- Turbo function to direct the heat flow towards
- Backlit display in blue which shows the selected functions and the ambient temperature
- Anti-tip switch
- Integrated side handles
- Body in painted steel
- Double insulated
- IP20 protection
- Heated area: 20 m²



CALDO TURBO / CALDO 2000

Residential



CALDO 2000

FEATURES

- Convector heater using natural convection
 - Model CALDO TURBO provided with a frontal grille to direct the heat flow forward
 - Adjustable ambient thermostat
 - Antifreeze function
 - Can be wall-mounted (wall installation kit supplied)
 - Body in painted steel
 - Double insulated
 - IP20 protection
 - Heated area: 20 m²
- Range:**
- CALDO 2000: one model including 3 heating levels: 750 / 1250 / 2000W
 - CALDO Turbo: 3 models with 3 heat setting each:
Caldo Turbo 1000: 350 / 650 / 1000W
Caldo Turbo 1500: 500 / 1000 / 1500W
Caldo Turbo 2000: 750 / 1250 / 2000W





VOLCANO R

Industrial



FEATURES

- Heaters ideally suited for heating small and medium sized industrial premises
- 2 models: 3,3 or 5 kW
- Manufactured in rugged steel cabinet with strong safety insulated handles
- Encapsulated stainless steel heating elements that are extra-insulated from the cabinet
- Provided with safety thermostat which guards against overheating and ensures that fire hazard does not arise
- Provided with room thermostat to maintain the desired temperature
- Selectable heating effect, between 1/2 and 1/1 through the selector switch
- The 5 kW model is provided with a CEE plug of 16A, 5 poles, IP44 while the 3kW model is provided with a Schuko plug of 16A IP44.

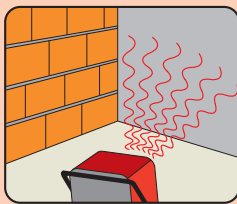

Asciugatura di parete in costruzione

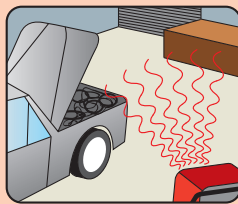

Officina

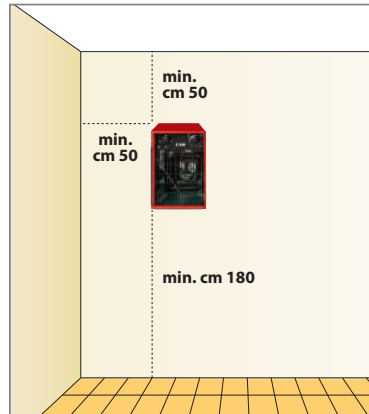

VOLCANO PRO

Industrial



FEATURES

- Heaters ideally suited for heating medium sized industrial premises
- 2 models: 6 or 9 kW
- Very compact and unique dimension for both models
- Housing in steel sheet
- Provided with delay start and delay stop functions, settable on the panel
- Provided with a cooling down post ventilation function (max 10 minutes)
- Provided with a CEE plug of 16A, 5 poles, IP44

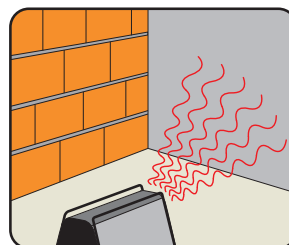

Asciugatura di parete in costruzione

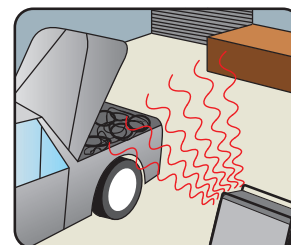

Officina



VENTILATION

RESIDENTIAL PREMISES



INDUSTRIAL AND SPORTS PREMISES

COMMERCIAL PREMISES



PRINCIPLE

In winter, in heated environments, the less dense hot air tends to accumulate in upper areas due to convection while in summer the gas emissions linked to the large quantities of energy consumed by air conditioning systems require a more attentive and aware attitude towards the environment.

BENEFITS

Ceiling fans are an excellent solution for cooling and heating environments. In winter fans installed on the ceiling are able to destratify the warm air accumulated in the upper areas of the room and to distribute it homogeneously with a consequent energy recovery.

In summer it is not only a reduction in temperature that contributes to cooling but also optimal air circulation: a ceiling fan spinning at low speeds increases the sensation of coolness, makes the air more breathable and reduces the energy costs arising from excessive use of the air conditioning system.

Unlike air conditioners, ceiling ventilation does not alter the temperature and humidity present in the environment and, if used in combination, enables the cooling potential to be fulfilled, allowing the system to be switched on for a less period of time and therefore reducing electricity consumption. It is therefore a simple solution to the energy saving requirement in rooms, industrial or sports environments, and in commercial spaces:

✓ **MP800 destratifiers and POLAR reversible ceiling fans from Maico Italia - Elicent® meet these functionality requirements and are extremely easy to install.**

Ventilation is a simple answer to the need for energy saving.

Simple and convenient
in winter as in summer

Winter

In heated rooms the hot air, which is lighter than the cold one, tends to accumulate in the high areas as a consequence of the convection effect.

The ceiling fans allow to stratify the warm air accumulated in the high areas of the room and to homogeneously distribute it, resulting in an efficient thermal recovery.

Summer

Gas emissions linked to the great amount of energy consumed by air conditioning systems require a more careful and aware attitude towards environment.

It is not only the decrease in temperature that helps to cool the room but also a good air circulation: a ceiling fan that runs at low speed increases the feeling of freshness, makes the air more respirable and reduces energy costs resulting from an excessive use of the air conditioning.

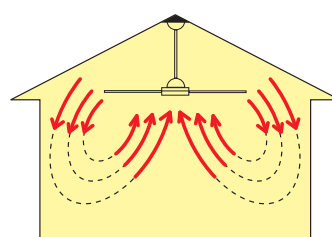

WINTER
(indirect ventilation)

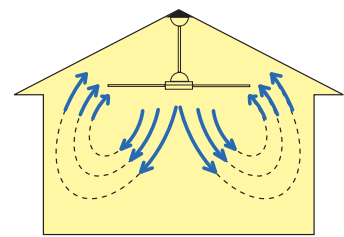

SUMMER
(direct ventilation)



POLAR EVOLUTION



REVERSIBILITY

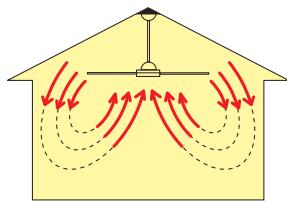

WINTER
direct ventilation

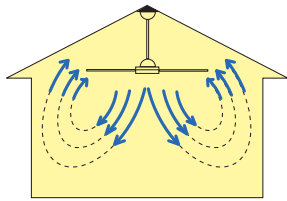

SUMMER
indirect ventilation



MODEL	DIAMETER (mm)	V at 50Hz	W	A	RPM	m³/h
POLAR EVOLUTION 90	900	230	65	0,25	390	5150
POLAR EVOLUTION 120	1200	230	80	0,33	330	10.080
POLAR EVOLUTION 140	1400	230	85	0,35	285	11.220
POLAR EVOLUTION 150	1500	230	90	0,38	280	13.140

DIMENSIONS

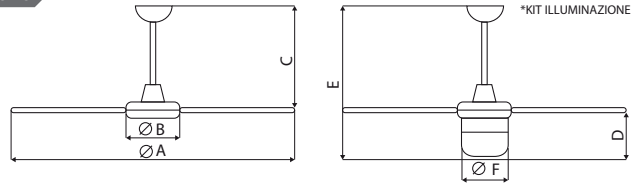

MODEL	Ø A	Ø B	C	D	E	Ø F	Kg
POLAR EVOLUTION 90/36	900	200	530	150	680	190	5
POLAR EVOLUTION 120/48	1200	200	530	150	680	190	5,4
POLAR EVOLUTION 140/56	1400	200	530	150	680	190	5,6
POLAR EVOLUTION 150/60	1500	200	530	150	680	190	5,9

ACCESSORIES



Light kit



Remote controller and receiver kit



RVS/L 5 speed controller with on/off and light switch. Max load 0,5 A. IP42 protection. Size 118x118x58 mm.



30 and 90 cm rods



RVS PLUS EVO: 5 speed controller with on/off switch. Regulation up to 4 POLAR. Max load 1,5 A. IP 42 protection. Size 158x118x76 mm.



MP800



- Single (230V) or three-phase (400V) motors
- Supplied with ceiling fixing chains
- Ideal for large heated premises
- Each scatter covers an area of 200 m²

VENTILATION Air Scatter



MODEL	m³/h	KW	RPM	PROTECTION IP	dB (A) (at 6 m)	Kg
MP800 single-phase	9000	0,14	450	55	54	26
MP800 three-phase	10500	0,12	530	55	59	25

DIMENSIONS

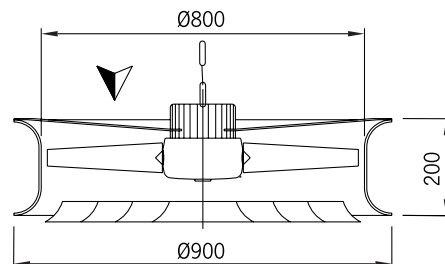

MODELLO	Ø A	B	Ø C
MP800	900	200	800



PRINCIPLE

The effectiveness of hand drying is an essential aspect for reducing the transmission of bacteria and other micro-organisms, as it is more likely to occur with wet skin than dry skin; in this respect certain studies have discovered that six times more bacteria grow on the surface of paper towel dispensers than on air-powered devices.

Paper towels are also systematically used in excess with consequent disposal and recycling expenses.

BENEFITS

Electric hand dryers and hair dryers offer the advantage of greater hygiene for the people using them, as direct contact is avoided and is replaced by a jet of hot air that is activated with a button or the photocell, drying the hands or hair while also giving a sensation of softness and cleanliness.

Their operation is ensured 24/7 and paper waste is avoided when using these devices instead.

Rooms in which they are installed are certainly cleaner and tidier, and for high-traffic areas they provide anti-theft and anti-vandalism peace of mind:

✓ In the next generation hand driers of the ECOJET Series from Maico Italia - Elicent® the jet of hot air is replaced with an air blade, which is much more powerful and comes out of several slots, ensuring quick drying in just 8 seconds; although the ECOFLOW Series has a traditional automatic functioning, being equipped with a high speed motor it ensures drying in just 12 seconds. Both series are free from electrical resistance and optimise electricity consumption, and are therefore particularly ecological

✓ The HD and HR Series from Maico Italia - Elicent® guarantee the advantages mentioned above and offer particular cost savings



THE ADVANCED QUALITY

7 Good reasons for choosing hand dryers as opposed to traditional drying systems

- 1 24/7 automatic service.
- 2 No costs of buying, supplying and disposing of paper towels.
- 3 High waste reduction: paper is usually overused, hand dryers are used only for the necessary drying time.
- 4 Restrooms look cleaner and tidier.
- 5 Antivandal models available for high traffic zones.
- 6 Higher hygienic standards, lower bacterial proliferation in the bathroom.
- 7 **Optimized used of energy:** reduced waste and carbon footprint.

THE ADVANCED QUALITY



COVER WITH ANTI-VANDAL LOCK

Steel one-piece vandal-proof cover, extremely robust and impact-resistant. The cover can be locked and removed for cleaning with the special wrench supplied. The special finishing in white epoxy SCRATCH-RESISTANT PAINT is ideal for a long-lasting quality and an efficient cleaning (even from spray paints or marker pens).



UV STABILIZED

Made of UV resistant ABS plastic. Protected with anti-aging and fire-proof paint UL94-V0.



LOW NOISE

The noise levels are among the lowest in this category of high efficiency dryers. The wall fixing plates are provided with an anti-vibration gasket.



QUICK DRY

The high efficiency of all models guarantee a quick dry without energy waste.



AUTOMATIC START-UP

Fitted with an infra-red sensor that starts the product automatically when hand enter the sensor detection field. The sensor is adjustable from 8 to 12 cm through the internal trimmer.



MANUAL START-UP

Pushbutton protected against improper and violent use. Air delivery operates for 35 seconds.



DOUBLE INSTALLATION

Class II products: no earth connection is needed.



QUICK INSTALL

A drilling ruler for a quick installation is supplied in each package. Simplified and secure lock of the cover thanks to the special wrench supplied.



ECO-FRIENDLY

Combines energy efficiency with an optimal drying time.

INSTALLATION FOCUS

Height distance from the floor

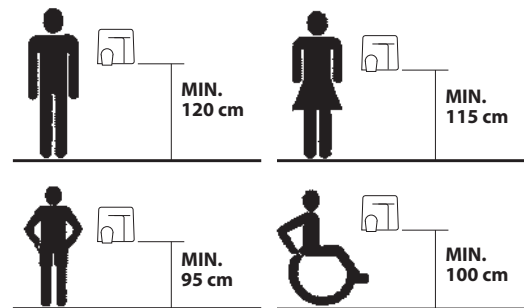

Minimum distance for serial mounting

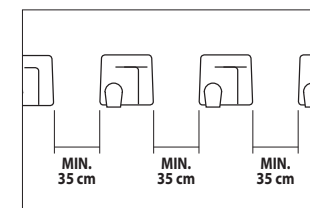

Minimum distance from the wall

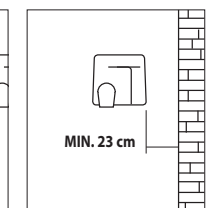

Conformity

EN 60335-1: 2002

"Safety of electrical appliances for domestic use and similar"

EN 60335-2-23

"Appliances for skin and hair care"

EN 50366

"Appliances for domestic use and similar. Electromagnetic fields: evaluation methods and measures"

2004/108/EC

EMC Directive (Electromagnetic compatibility)

2006/95/EC

Low Tension Directive



White finish

Inox finish



TECHNICAL SPECIFICATION

RPM	30.000
Air velocity (Km/h)	410
Air temperature	40°C
Power (W)	420 - 1.100
Consumption (A)	3,2 - 5
Noise level (dBA) at 2 m	65 - 68
Volt	220 - 240
Hz	50 - 60
Insulation	Class I
Estimated drying time	8 - 10 sec.
Weight (Kg)	8,3
Protection	IPX4

FEATURES

- Exclusive design
- ABS cover
- 4 air scatterers
- 2 IR sensors
- Drying time: 8 sec
- Air velocity: 410 km/h at 40°C
- **Energy saving: no heating element**

- Hand dryer of new generation: fast drying, energy efficient, ecologic, hygienic and stylish.
- "Hands in" model. Provided with 2 pairs of IR sensors on both sides of the upper covers for instant hand detection.
- High speed motor. Motor power adjustable. Class F.
- Cover in anti-scratch ABS and aluminium impeller.
- Available in white or satin grey finish.

Eco-friendly and efficient

- Dries hand in 8 to 10 seconds according to the motor speed 8adjustable via an internal trimmer).
- Low energy consumption thanks to the absence of the electric heating element: the efficient drying is given by the velocity and the type of air diffusion and not by the hot temperature as in more conventional driers.
- Lowest noise level in its category.

Hygienic and safe

- The internal surface and the water tank coated with the exclusive Biocote® antimicrobial and antibacterial protection technology based on silver ions. These ions inhibit the reproduction of micro-organisms in the product throughout its lifetime.
- No water dripping onto the floor. Water tank of 0,675 capacity, easily removable for cleaning.
- Provided with an acoustic warning for full tank.
- Easy to maintain: the front casing can be easily removed to access the internal components, quick cleaning of filters, removable water tank, with external valve for easy emptying. All as part of an ergonomic design that facilitates regular cleaning.



Warning lights for a quick diagnosis of the dryer.



4 air diffusion layers for an ultra-fast drying.



Air speed adjusting trimmer.



Water tank easily removable from the external side.



Dry hands in 8 seconds!

DIMENSIONS (mm)

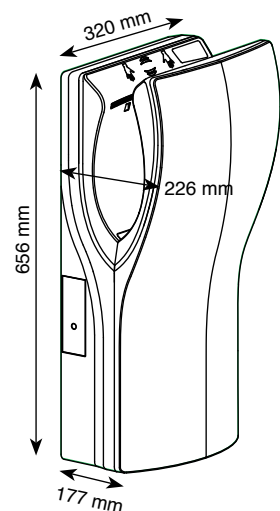



ECO FLOW
Automatic
steel white finish

ECO FLOW X
Automatic steel inox



TECHNICAL SPECIFICATION

Airflow (m3/h)	187
RPM	19.000 - 30.000
Air velocity (Km/h)	325
Air temperature	40° C
Motor power (W)	420 - 1150
Consumption (A)	3,3 - 4,7
Noise level (dBA)	68-75 dB
Volt	220-240 V
Hz	50-60
Insulation	Class I
Estimated drying time	12 sec
Weight	4,7 Kg
Protection	IP23

- Compact, one-piece steel cover
- Sensor operated for a complete automatic operation
- Drying time: 8-12 sec.
- Air velocity: 325 km/h at 40°C
- **Energy saving: no heating element**

FEATURES

- Energy efficient antivandal hand driers.
- Compact, one-piece steel cover.
- IR sensor operated for a complete automatic operation. Distance detection is adjustable by potentiometer (5-25 cm).
- High-speed adjustable motor, Class F.
- Available in white or steel finish.

Eco-friendly and efficient

- Ultra-fast drying time: 8-12 seconds according to the motor speed (adjustable via internal trimmer).
- Low energy consumption thanks to the absence of the electric heating element: the efficient drying is given by the velocity of the air (325 km/h) and not by its temperature as in more conventional driers.
- Noise registered is at the lowest level among the range of high velocity fans.

Robust and safe

- Antivandal construction in steel with frame in ABS with high mechanical resistance. Provided with silent block to reduce the mechanical vibrations.
- Automatic switch off of the dryer after 60 seconds of continuous use.

DIMENSIONS (mm)

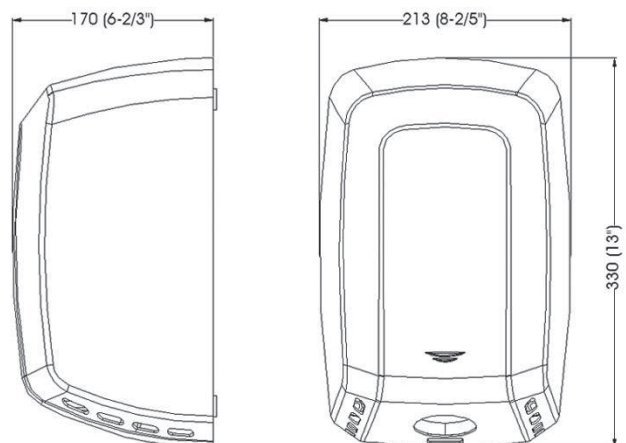



HD300

HYGIENE Antivandal HAND-DRYERS



HD300A

Automatic white or inox finish



Sensor operated

(adjustable through internal trimmer)
Optimized energy consumption:
immediate stop after the hands are removed.



Steel
AISI 304

HD300P

Manual white or inox finish



Push-button activation

(electronic timer with a 35 seconds cycle)



TECHNICAL SPECIFICATION

Airflow (m³/h)	330
RPM	5500
Air velocity (Km/h)	96
Air temperature	53°C
Motor power (W)	250
Resistance (W)	2000
Consumption (A)	10
Noise level (dBA)	68
Volt	220-240
Hz	50/60
Insulation	Class I
Estimated drying time	25 sec
Weight Kg	4,9 Kg (A) - 4,65 Kg (P)
Protection	IP23

FEATURES

- Compact, steel one-piece cover white epoxy coated and anti-scratch painted, 1,5 mm thick.
- Cover fixed to the base by means of 2 vandal-proof lock screws and locked with a special wrench supplied.
- Base in aluminium with anti-vibration supports, 3 mm thick, with 4 ø8 mm holes for wall mounting.
- Chrome-plated 360° revolving vandal-resistant nozzle, for hand and face drying.
- Warm airflow (53°C) at high velocity (96 Km/h) for a quick drying.
- Fire-resistant UL94-V0 impeller casing.
- High efficiency centrifugal impeller in aluminium.
- Waved wired NiCr heating element with self-resetable thermal cut-off.
- Universal brush motor, class F, incorporating a safety thermostat and a self-resetable thermal cut-off at 120°C.



**360°
ORIENTATION**
Dries hands and face

- One-piece cover stainless steel
- For high traffic facilities
- Manual or Automatic versions



Vandal-proof lock system
(wrench supplied).



Internal trimmer
to set the sensor.



High efficiency
centrifugal impeller
in aluminium.

DIMENSIONS (mm)

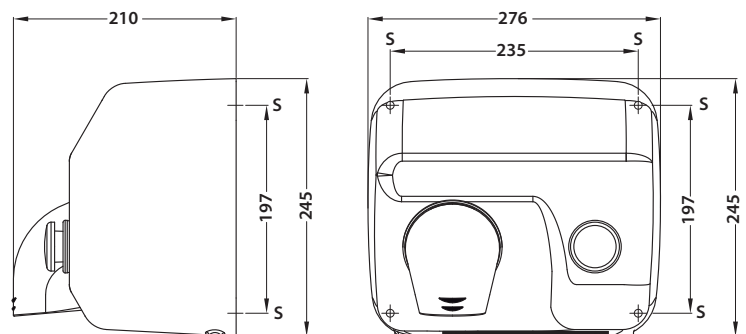



HD100

HYGIENE Hand Dryer CLASSIC



HD100P
Manual

HD100A
Automatic



TECHNICAL SPECIFICATION

Airflow (m³/h)	240
RPM	2.800
Air velocity (Km/h)	65
Air temperature	52°C
Motor Power (W)	140
Heating element power (W)	1500
Consumption (A)	7
Noise level (dBA)	58
Voltage (V)	220-240
Frequency (Hz)	50/60
Electrical insulation	Class II -
Drying time	35 sec
Weight Kg	3 Kg
Protection	IP21

- Classic design
- Compact
- Manual or Automatic versions
- Medium traffic facilities

FEATURES

- Compact, one-piece cover made of UV resistant ABS white plastic, 3 mm thick.
- Cover fixed to the base by 4 screws.
- Air outlet grille in Zamak.
- Manual start-up through pushbutton which activates an electronic timer with a 40 seconds cycle.
- Warm airflow (52°C) at high velocity (65 Km/h) for a quick drying.
- Housing and impeller in fire-resistant ABS plastic UL 94-V0.
- Waved wired NiCr heating element with self-resetable thermal cut-off.
- Class F motor, incorporating a safety thermostat and a self-resetable thermal cut-off at 70°C.

DIMENSIONS (mm)

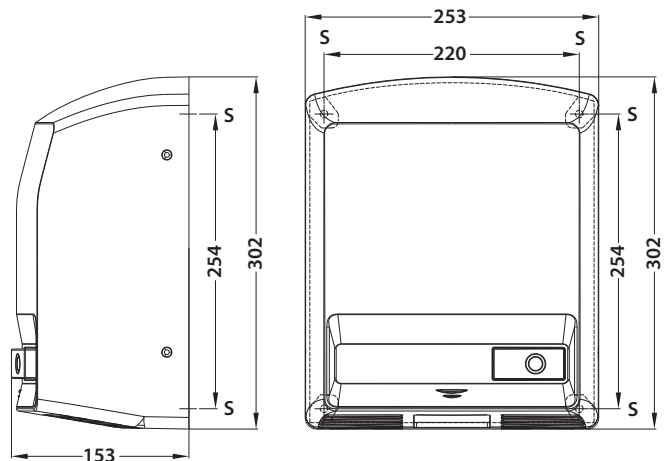

S = screw holes



HR100

HYGIENE Wall-mounted hair dryer



TECHNICAL SPECIFICATION

Airflow (m ³ /h)	40
RPM	15.000
Air velocity (Km/h)	79
Air temperature	60°C
Motor Power (W)	150
Heating element power (W)	700
Consumption (A)	3
Noise level (dBA)	60
Voltage (V)	220-240
Frequency (Hz)	50/60
Length tube (mm)	800 - 2000 mm
Weight Kg	1,8 Kg
Electrical insulation	Class II -
Protection	IP23

FEATURES

- Quick and easy installation.
- Automatically activates when hand piece is removed from base.
- Fitted with a special security system which switches off the dryer after 15 min of use.
- High velocity airflow (79 Km/h) for a quick drying.
- White ABS plastic one-piece cover , 3 mm thick, impact-resistant and UV protected.
- The polyurethane extensible tube follows your movements while drying.
- PP UL 94-V0 helicoidal fan wheel.
- White ABS handset with a thermal protector inside.
- White ABS support and fixing.
- Motor, class B, with thermal protection.
- Waved NiCr wire heating element that incorporates a self-resetable thermal cut-off.

- Elegant and compact design
- Safe and efficient

DIMENSIONS (mm)

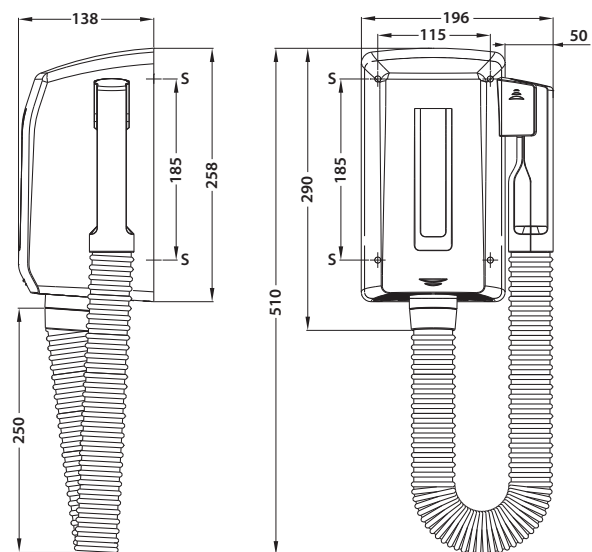

SENSORS AND CONTROLLERS

R10 series



SENSORS



R10 TIMER
Remote timer

- **Electronic timer, adjustable from 3 to 25 minutes**
- The fan to which it is connected will overrun after switch-off for the pre-set time.
- Time adjustment via external knob
- ON/OFF light switch
- New design with protection cover
- Suitable for surface and built-in installation
- Ease of connection by means of removable terminals
- Preset holes for surface or recessed cable entry
- **Max load 4 A**
- Single-phase 117-230V / 50-60 Hz
- Class II protection, no earth connection is needed
- **Provided with protection fuse**
- Weight: 0,5 Kg
- Dimensions 110x80x42 mm



R10 HY
Remote Humidity Sensor

- The sensor **automatically** switches ON/OFF the fan according to the detected level of relative humidity, **adjustable from 40 to 90%**.
- The permanent control of the humidity level offers important advantages: maximum comfort for the user and energy saving as the fan is activated only if necessary.
- Suitable for surface and built-in installation
- Ease of connection by the means of removable terminals
- Preset holes for surface or recessed cable entry
- **Max load 4 A**
- Single-phase 117-230V / 50-60 Hz
- Class II protection, no earth connection is needed
- **Provided with protection fuse**
- Weight: 0,5 Kg
- Dimensions 110x80x42 mm



R10 P.I.R
Remote Passive Infrared Sensor

- The fan goes on any time the sensor detects a human presence in the room
- **Provided with integral delay timer adjustable from 3 to 25 minutes**, which keeps the fan running for the pre-set period after the room is vacated
- **Ideal solution for public toilets**
- The green led indicates that the sensor is detecting
- Suitable for surface and built-in installation
- Ease of connection by means of removable terminals
- Preset holes for surface or recessed cable entry
- **Max load 4 A**
- Single-phase 230V / 50-60 Hz (different voltage upon request)
- Class II protection, no earth connection is needed
- **Provided with protection fuse**
- Weight: 0,5 Kg
- Dimensions 110x80x42 mm



R10 AQS
Remote Air Quality Sensor

- The sensor reacts to tobacco smoke and unpleasant odours
- **It automatically switches the fan ON/OFF according to the detected air quality level, manually adjustable.**
- Suitable for surface and built-in installation
- The permanent control of indoor air quality offers important advantages: maximum comfort for the user and energy saving as the fan is activated only if necessary.
- **Ideal for public premises**
- Ease of connection by the means of removable terminals
- Preset holes for surface or recessed cable entry
- **Max load 4 A**
- Single-phase 117-230V / 50-60 Hz
- Class II protection, no earth connection is needed
- **Provided with protection fuse**
- Weight: 0,5 Kg
- Dimensions 110x80x42 mm



CO₂ Sensor

- The fan automatically starts running when the sensor detects a CO₂ concentration included in a range from 500 to 2000 ppm
- Provided with 5 LED that indicate the level of CO₂ concentration in the air
- Voltage : 14 V - 48 V DC / 16 V - 36 V AC
- Ampere: I_{nom} 0,02 / I_{max} 0,1
- Protection IP20
- Suitable for ambient temperature from 10°C to 40°C
- Dimensions (Lxpxh): 79x30x120 mm
- Weight 0,1 kg

SENSORS AND CONTROLLERS

ELECTRONIC CONTROLLERS



SPEED CONTROLLERS



R10

- Infinitely variable electronic speed controller by potentiometer
- New design with cover
- **Suitable for surface and built-in application**
- Ease of connection by the means of removable terminals
- External trimmer for the adjustment of the fan minimum speed
- Protection fuse
- Preset holes for surface and recessed cable entry
- Single-phase 230V – 50 Hz
- **Max. load 1A**
- Protection IP42
- Weight 0,5 Kg
- Dimensions 110x80x42



R15

- Infinitely variable electronic speed controller by potentiometer
- New design with cover
- ON/OFF light switch
- **Suitable for surface and built-in application**
- Ease of connection by the means of removable terminals
- External trimmer for the adjustment of the fan minimum speed
- Protection fuse
- Preset holes for surface and recessed cable entry
- Single-phase 230V – 50 Hz
- **Max. load 1,5 A**
- Protection IP42
- Weight 0,5 Kg
- Dimensions 138x80x42



RV1

- Electronic speed controller
- Infinitely variable speed control by potentiometer.
- ON/OFF switch
- IP42 protection
- **Max. load: 800 W (4A)**
- **Min. load: 400 W (1A)**
- Supply voltage: 230V-50 / 60 Hz
- Sizes: 110x100x58 mm
- Weight: 0,5 kg

CONTROLLERS WITH TRANSFORMER



SPEED CONTROLLERS



RLS
2 speeds

- **Speed control (Min/Max) and On/Off switch**
- New design with cover
- **Suitable for surface or built-in installation**
- Ease of connection by the means of removable terminals
- Protection IP42
- Weight 0,40 Kg
- Supply voltage 230V – 50/60 Hz
- Dimensions 110 x 80 x 42



RLS 3V
3 speeds

- **Remote 3 speed control (Min/Max) and On/Off switch**
- New design with cover
- **Suitable for surface or built-in installation**
- Ease of connection by the means of removable terminals
- Protection IP42
- Weight 0,40 Kg
- Supply voltage 230V – 50/60 Hz
- Dimensions 110 x 80 x 42



RVS
5 speeds

- **5 steps speed controller (fitted with transformer)**
- ON/OFF switch
- IP42 protection
- **Max. load: 100 W (0,5 A)**
- Supply voltage: 230V-50/60 Hz
- Sizes: 118 x 118 x 58 mm
- Weight: 0,7 kg



RVS/R
3 speeds

- **Reversible speed controller**
- ON/OFF switch
- IP42 protection
- **Max. load: 0,5A**
- Supply voltage: 230V-50/60 Hz
- Sizes: 118 x 118 x 58 mm
- Weight: 0,7 kg



RVS/R
5 speeds

- **Reversible speed controller**
- ON/OFF switch
- IP42 protection
- **Max. load: 0,5 A**
- Supply voltage: 230V-50/60 Hz
- Sizes: 118 x 118 x 58 mm
- Weight: 0,7 kg



RVS/R PLUS
6 speeds

- **Reversible multi controller**
- Regulation up to 5 pcs of VITRO 9 or 3 pcs of VITRO 12 contemporaneous.
- ON/OFF switch
- IP42 protection
- **Max. load: 1,5 A**
- Supply voltage: 230V-50/60 Hz
- Sizes: 158 x 118 x 76 mm
- Weight: 1,8 kg



RLS 1 WR

- **Remote controller**
- Manual selection of three modality of continuous running:
 - I - Low ventilation modality
 - II - Intermediate ventilation modality
 - III - Intensive ventilation modality
- supply voltage 230V – 50/60 Hz
- Weight 0,50 Kg
- Dimensions 75 x 75 x 30

Supplied with
REC in linea EC 140 - 180 - 220 / REC 320
Accessory for EC versions of Microbox and Multibox.



CP

- **Continuous speed Controller**
- Suitable for Microbox and Multibox Control



TOUCH PANEL
Touch panel controller with coloured screen

The panel allows to manually or automatically manage (through the weekly programming) the following functions:

- The Speed/ventilation level regulation
- The ventilation modality (by-pass function, free-cooling, only extraction, only immission)
- The threshold humidity level over which the unit increases its speed
- The post-ventilation function (Timer function, adjustable from 0 to 30 minutes) to delay the switching of the unit at the minimum speed)
- The Sleep modality that allow to have the unit running silently at low speed during the night
supplied with REC in linea TC, REC 320 TC



REMOTE CONTROLLER
Remote radio controller to manage the following functions

Through the remote radio controller it is possible to manage the following functions:

- On/Off
- The Speed/ventilation level regulation
- The Sleep modality that allow to have the unit running silently at low speed during the night (the boost function is excluded)
- The post-ventilation function (Timer function, adjustable from 0 to 30 minutes) to delay the switching of the unit at the minimum speed
supplied with REC DUO 100 Plus AC

E-VSD



VARIABLE SPEED DRIVE

Controller that continuously adapts the electrical power supplied to the motor in order to regulate the ow rate through the control panel interface **CP-RH** or **CP-AQS**

CHARACTERISTICS

Supply: 220 - 240 Vac ; 50/60Hz.

Maxim un Power: 300 W

W a terproof: IPX4

Main materials: Aluminium cover

Selfestingishing casing (UL - 5VA) for surface mounting installation

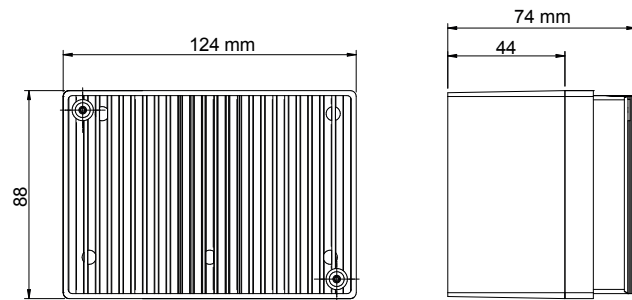

CONTROL PANEL



CP-RH



CP-AQS

CHARACTERISTICS

Control panel:

Measures a set of (control) parameters representative of the ventilation demand / quality of the indoor air.

Interface with E-VSD controller.

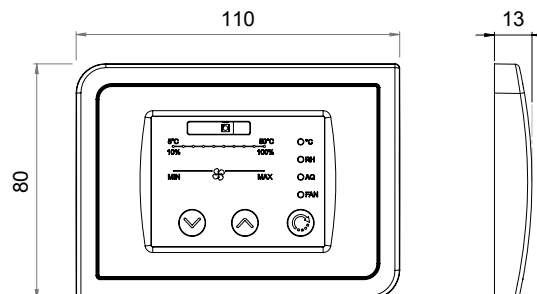

FUNCTION:	CP-RH	CP-AQS
Temperature control	●	●
Relative humidity detection	●	●
Air quality control		●
Continuous Speed Regulation	●	●

Choose the right controller

FANS	TRANSFORMER				ELECTRONIC	BUILT-IN ELECTRONIC			
	RVS	RVS1	REVERSIBLE			RLS	RV1	R10	R15
			RVS/R 3V - 5V	RVS/R PLUS					
AXC 100 A/B - 125 A/B - 150 A - 160 A	●						●		
AXC 150 B - 160 B		●					●	●	
AXC 200	●						●	●	
AXC 250		●					●	●	
AXC 315		●							
AXC 355 A		●						●	
AXC 355 B						●			
AXC TP 100-125-150-160	●						●		
AXM 100 - 125 - 150 - 160 - 200	●						●		
BUILT-IN 9		●	●	MAX 5					
BUILT-IN 12		●	●	MAX 3					
ECO LINE	●						●		
E-MAX	●				● 2V		●		
ELEGANCE	●						●		
ELIX	●						●		
ELPREX	●						●		
E-SMILE	●						●		
E-STYLE	●						●		
EXT 100 - 125 - 150 A - 160 A	●						●	●	
EXT 150 B - 160 B - 200 A/B							●	●	
JOLLY	●						●		
FLUX	●						●		
MICROBOX 3V					● 3V				
MULTIBOX 3V					● 3V				
MINISTYLE	●						●		
MURO	●						●		
MRF 100 - 125 - 150	●						●	●	
MRF 160 - 200 - 250		●					●	●	
MRF 315		●							
RADIA	●						●		
TUBO	●						●		
VITRO 6/150 A	●						●		
VITRO 9/230 Automatic / Reversible		●	●	MAX 5					
VITRO 12/300 Automatic / Reversible		●	●	MAX 3					

HRU	TOUCH PANEL 2RV4167	REMOTE CONTROLLER 5SL0022	RLS 2RV4158	RLS 3V 2RV4168	RLS 1 WR 2RV1003	CP 2RV4171	CP AQS 2RV4180	CP RH 2RV4179
REC Duo 100 - DUO 100 MHY			●					
REC Duo 100 PLUS RC		● (included)	●					
REC Smart standard			●					
REC Smart MHY			●					
REC Smart Plus RC		● (included)						
REC Smart Plus TC	● (included)							
REC in linea 180 AC				●				
REC in linea 220 AC				●				
REC in linea 140 EC	●				● (included)			
REC in linea 180 EC	●				● (included)			
REC in linea 220 EC	●				● (included)			
REC in linea 140 EC Plus TC	● (included)							
REC in linea 180 EC Plus TC	● (included)							
REC in linea 220 EC Plus TC	● (included)							
REC 280 AC				●				
REC 320 EC	●				● (included)			
REC 320 PLUS TC	● (included)							
MICROBOX - MULTIBOX 3V				●				
MICROBOX CONTROL - MULTIBOX CONTROL						●		
MICROBOX CONTROL+ AQS - MULTIBOX CONTROL+ AQS							● (included)	
MICROBOX CONTROL+ HY - MULTIBOX CONTROL+ HY								● (included)
MICROBOX EC AQS - MULTIBOX EC AQS							● (included)	
MICROBOX EC HY - MULTIBOX EC HY								● (included)

Accessories

	AL Back-draught shutter.	MINISTYLE E-STYLE		LIGHT KIT	POLAR
	SA Back draught shutter.	AXC MET AXC TP AXM		KIT RVS/RVS-R Built-in wall kit for RVS and RVS-R speed controllers.	
	CA Outlet connection piece with back draught shutter ø 100-120 mm.	FLUX		FILTER Metal grease filter	E-SMILE FLUX RADIA
	SG Safety grille.	AXC MET AXM		WINDOW KIT Window kit with external fixed grille.	ECO GG ECO A
	PL Wall cover plate.	MINISTYLE ECO GG-GF-A		WINDOW KIT Window kit with external gravity shutter.	ECO GF
	WPL WALL CONNECTING PLATE for round pipe	ø 100 mm ø 125 mm ø 150 mm		MGE External gravity shutter.	MINISTYLE TUBO ECO GF
	SF Kit for double window installation.	VITRO		MFE External fixed grille.	E-SMILE / MINISTYLE TUBO / E-STYLE ECO GG ECO A
	SM Kit for wall installation.	VITRO		BCR White Round grille with net.	ø 100 mm ø 125 mm ø 150 mm ø 200 mm
	SV Kit for double glazed window installation.	VITRO		BC VENTILATION WHITE ROUND GRILLE for indoor and outdoor use, for furniture, doors, fillings and vent pipes, whitout flyscreen	ø 100 mm ø 125 mm ø 150 mm ø 200 mm
	SX Wall fixing brackets.	AXC MET		Transformer for SELV products	
	SXP Wall fixing plate for TP centrifugal in line fans.	AXC TP		BEIP inlet/outlet round ventilation grille	Ø 100 mm Ø 125 mm
	FA Hose clamps.	AXC MET AXC TP		BEA ventilation grille	30 m3/h Ø125 mm 60 m3/h Ø125 mm
	SIL Silencers.	AXC MET		BH humidity controlled ventilation grille	10/60 m3/h
	SHAFTS cm 30 cm 43 cm 90	POLAR			

A wide range of ducts and accessories for heat recovery ventilation is also available.

**Air is like music: you can't see it but
you can surely appreciate the quality.**





Maico Italia Headquarters in Lonato del Garda (Brescia), Italy



Maico Italia S.p.A.

Via Maestri del Lavoro, 12 - 25017 Lonato del Garda (Brescia) Italia
Tel. +39 030 9913575 - Fax +39 030 9913766

sales@maico-italia.it / www.elicent.it



Member of:



We reserve the right to modify any technical data without notice.
Different voltage and frequency upon request.

All trademarks are the property of Maico Italia Spa - All rights reserved.

Follow us:

