

# AIRTRONICS

Designed and inspired in Sweden

## FAN COIL UNIT CENTRAL AIR-CONDITIONING

ACR ATC  
AFM AKM  
ARQ



**AHRI** CERTIFIED®  
www.ahridirectory.org  
Central Station Air-Handling Unit Casings  
AHRI Standard 1350

# FEATURES

## Superior Product Quality



All fan coil units are manufactured in a ISO9001:2000 and ISO14000:2004 certified manufacturing facility whereby highest products quality is always top priority. The products' quality standard has been recognized through successfully obtaining the CE marking certification which in turn comply with the stringent EU requirements

## High Efficiency Heat Exchanger

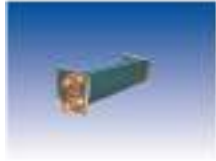

High quality copper pipes with slit profile aluminum fins are being transformed into high efficiency heat exchanger through advance design, manufacturing equipment and processes.

## Low Noise



Through straight static and dynamic balancing tests of motors, coupled with high quality thermal and acoustic insulation in the unit. Superb low noise performance is achieved.

## No leakages

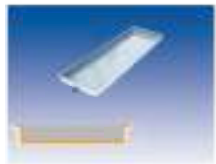

One piece molded drain with integral thermal insulation and professional welding skill enable all condensate water to be collected and prevent condensation at the outside of the drain pan.

## Use High Efficiency DC Motor



High efficiency, average consumed power is 50% of common motor, leading low operation cost of air conditioner. Avoiding noise from carbon brushes. It is much silent when operating under medium speed.

## Multiple ESP Options



Standard fan coil units come with low ESP(12Pa) and high ESP(30Pa,50Pa), options to suit different applications .In addition, 80Pa fan coil units are available as non-standard options. High air volume FCU comes with standard ESP and high ESP options to add to the product line up.

## Slim And Compact Design





Light and rigid construction due to the compact and strong structural design of the unit .Slim unit design also fulfills the stringent space requirement of today building design. High air volume FCU with the height of only 430mm is most suitable for applications that demand for high air flow but with space saving in mind.

## Easy Maintenance



The fan coil unit are equipped with high quality electric motor with low noise bearing that do not require lubrication and thus minimum maintenance effort required. Blowers and also motors can be dismantled individually if cleaning of heat exchanger is needed. High efficiency filter provides better filtration than normal filter with longer operational life and easy to clean.

LCD Thermostat	TA108 Series	TA108DB2	Two-pipe system/220V/three-speed fan/three-wire valve/water valve closed and fan turned off when the temperature is reached	
		TA108DA2	Two-pipe system/220V/three-speed fan/three-wire valve/water valve closed but fan continues running when the temperature is reached	
TE316 Series			<ul style="list-style-type: none"> <li>● Touch screen operation</li> <li>● 3 fan speeds, AC and DC fan coils both available</li> <li>● Optional RS485 interface for group control</li> </ul>	
Motorized Valve	TA-G Series	TA-G2-3/4-S2	<ul style="list-style-type: none"> <li>● Driver and valve body can be quickly removed and installed easily without using any tools;</li> <li>● Applicable to various cooling/heating coil control systems; convenient, reliable, easy to install;</li> <li>● Two-/Three-way valve optional; multiple voltages available for the driver;</li> <li>● Driven by the hermetic unidirectional hysteresis synchronous motor and reset by a stainless steel spring; valve body formed by forging and pressing brass, stainless steel base and aluminum housing, ensuring reliability and long service life of the product.</li> </ul>	
		TA-G3-3/4-S2		

Airtronics has a series of optional accessories for different requirements on the

No.	Options	ACR	ARQ	ATC-A	ATC-B	AKM-C	AFM
1	Liquid Crystal Thermostat	"TA108 series TE316 series"	TE316 series	x	"TA108 series TE316 series"	x	"TA108 series TE316 series"
2	Wired Controller	x	x	x	x	90C series	x
3	Motorized Valve	TA series	TA series	TA series	TA series	TA series	x

Note:

1. AATC-A and AKM-C are provided with remote controllers;
2. Contactor is required when installing AFM liquid crystal thermostat;
3. The two-way valve of two-wire system needs to be selected for ATC-A and AKM-C.

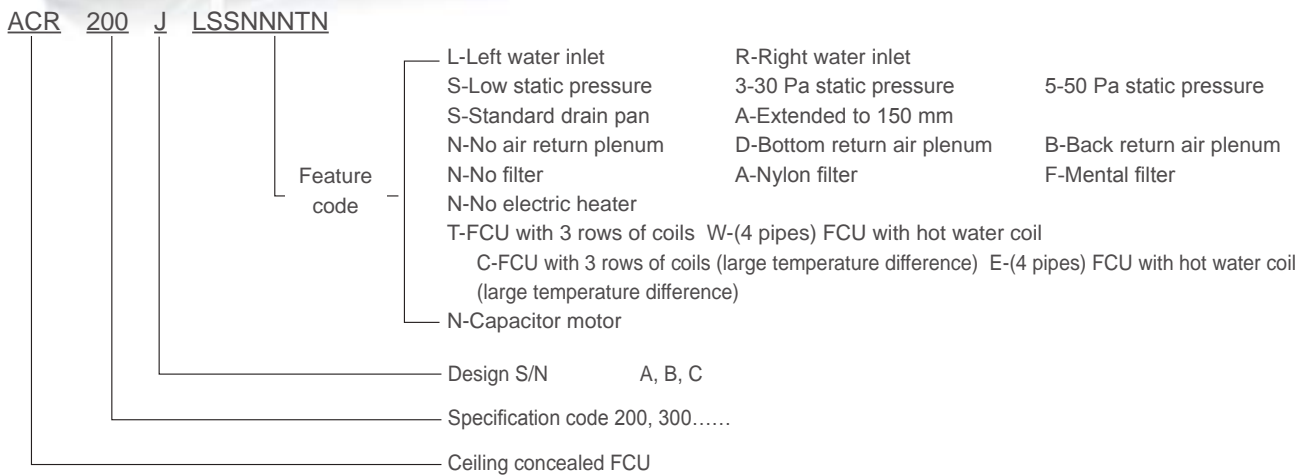

**1. Different ESP for option**

12Pa,30Pa,50Pa is standard,and 80Pa can be customized.

**2. Multiple coils design**

Two-pipe system (3 rows) and four-pipe system (3+1) are available.

**3. Return air purifiers as optional to make environment clean**

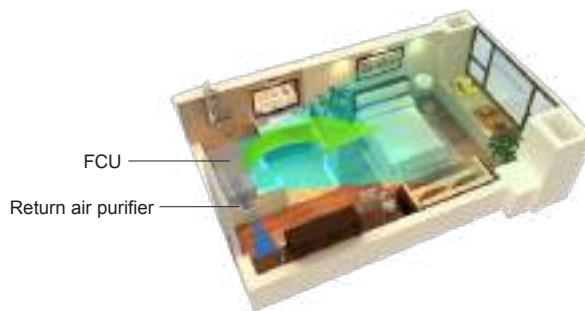
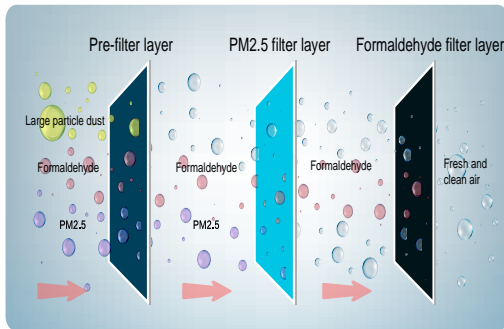

**Operating principles:**

The pre-filter layer removes hair, dust, and large particles from the air; the professional PM2.5 filter layer adopts the unique electrostatic technology to remove PM2.5 from the air through physical adsorption measures, without causing ozone hazard; the capture agent on the formaldehyde filter surface shows a formaldehyde removal capacity more powerful than that of the traditional activated carbon net, and converts the formaldehyde in air into a kind of safe and harmless substance through chemical reaction, instead of releasing it into the room with air and without leading to secondary pollution because of filtration adsorption and heating.

## Ceiling Concealed FCU (3 Rows)

Model: ACR		200J	300J	400J	500J	600J	700J	800J	1000J	1200J	1400J	
Rated Air Flow (m³/h)	High	340	510	680	850	1020	1190	1360	1700	2040	2380	
	Medium	270	380	510	640	780	880	1030	1290	1540	1850	
	Low	190	280	340	450	560	610	740	890	1040	1255	
Cooling Capacity (W)	High	2210	3200	4150	5000	5950	6600	8100	9100	11250	13000	
	Medium	1990	2782	3570	4197	5200	5600	6882	8200	9613	11700	
	Low	1635	2304	2950	3298	4200	4600	5749	6700	7403	7560	
Sensible Cooling Capacity (W)	High	1590	2285	2880	3570	4200	4700	5880	6700	8260	9750	
	Medium	1400	1920	2420	2930	3570	3900	4880	5700	6935	8280	
	Low	1050	1555	1930	2210	2900	3200	3935	4500	5120	5945	
Heating Capacity (Water Inlet: 60°C) (W)		High	3500	5200	6500	7870	9800	10900	13570	14900	18800	
Heating Capacity (Water Inlet: 45°C) (W)		High	2210	3200	4150	5000	5950	6600	8100	9100	11250	
Power Input (W)	Low Static Pressure (12Pa)	High	30	45	55	72	93	100	128	147	183	221
		Medium	27	36	43	58	80	97	112	130	165	198
		Low	23	30	35	48	68	78	95	110	136	165
	30 Pa	High	38	55	65	82	100	120	148	169	206	245
		Medium	32	45	50	64	80	105	133	160	195	230
		Low	27	33	37	53	70	90	128	140	170	195
	50 Pa	High	45	64	75	91	114	130	165	200	243	290
		Medium	36	50	65	86	105	110	150	190	230	270
		Low	30	42	55	73	90	96	122	170	200	250
FCEER	Low Static Pressure (12Pa)	High	65	64	66	61	55	57	55	53	50	
	30 Pa	High	53	53	57	55	51	48	48	47	45	
	50 Pa	High	45	46	50	50	46	45	44	40	39	
FCCOP (Water Inlet: 60°C)	Low Static Pressure (12Pa)	High	103	104	103	96	90	93	91	87	84	
	30 Pa	High	84	87	89	86	85	80	80	77	77	
	50 Pa	High	72	75	78	78	76	74	73	66	67	
FCCOP (Water Inlet: 45°C)	Low Static Pressure (12Pa)	High	65	64	66	61	55	57	55	53	50	
	30 Pa	High	53	53	57	55	51	48	48	47	45	
	50 Pa	High	45	46	50	50	46	45	44	40	39	
Sound Level (dB(A))	Low Static Pressure (12Pa)	High	35	38	39	41	45	46	46	47	49	51
		Medium	28.5	30	31	32	37	40	40	41	44	47
		Low	20.5	21	22	24	28	31	31	32	34	35
	30 Pa	High	38	41	42.5	45	46.5	48	47	49	51	52
		Medium	30.5	32	34	36.5	38.5	41	41	43	46	48
		Low	23	22	22	27.5	30	32	32	34	35	36
50 Pa	High	42	43	45	47	49	50	50	52	53	53	
	Medium	35.5	36	38	38.5	40	44	44	46	47.5	49	
	Low	29	28	28	29	31	36	36	38	40	42	
Sound Level* (dB(A))	30 Pa	High	36	39	40	43	44	46	46	47	49	50
		Medium	29	30	32	35	36	40	40	41	45	46
		Low	22	21	21	26	27	31	31	32	34	35
	50 Pa	High	40	41	43	45	47	48	48	49	51	51
		Medium	33.5	34	36	36.5	39	42	42	45	46	47
		Low	27	26	26	27	30	34	34	37	39	40
Fan	Type	Forward-curved multi-blade double inlet centrifugal fan										
Motor	Type	Single-phase capacitor motor										
Heat Exchanger	Structure Type	Efficient double-flanged aluminum fins and copper tubes, expanded into one										
	Maximum Operating Pressure (MPa)	1.6										
	Water Inlet/Outlet Pipe Diameter	Rc3/4 (Taper Pipe Female Threaded)										
Water Resistance	Water Flow (m³/h)	0.42	0.55	0.72	0.87	1.05	1.12	1.39	1.67	1.9	2.23	
	kPa	25	25	30	30	40	40	40	40	40	50	
Drain Pan	Condensate Water Pipe Diameter	Rc3/4 (Taper Pipe Male Threaded)										
Dimensions (Without Return Air Plenum)	Length (mm)	695	845	930	995	1085	1235	1530	1530	1795	1795	
	Width (mm)	470	470	470	470	470	470	470	470	490	490	
	Height (mm)	230	230	230	230	230	230	230	230	250	250	
Net Weight	Air Return Plenum (Excluded) (kg)	10.5	12.5	14.5	16	17	18.5	22	25	30	31.5	
	Air Return Plenum (Included) (kg)	12.5	15.5	17.5	19	20	22.5	26	29	36	37.5	

★ Note:

1. Cooling: supply water and return water temperatures 7/12°C; the dry/wet bulb temperature of air inlet is 27/19.5°C;
2. Heating: supply water is 60°C or 45°C, water quantity being the same as during cooling; air return conditions: the dry bulb temperature of air inlet is 21°C;
3. In the table, low static pressure indicates the air outlet static pressure at 0Pa (with air outlet and filter) and at 12Pa (without air outlet and filter);
4. The air flow in the table is obtained when the unit is running in dry state and the dry bulb temperature of air inlet is 20°C;
5. In the table, noise is measured according to Figure C.2 in GB/T 19232-2019 in a semi-anechoic room where the background noise is 11.5 dB(A);
6. In the table, noise is measured according to GB/T 19232-2019 in a semi-anechoic room where the background noise is 11.5 dB(A);
7. Left & right swing manner can be adjusted on site. After adjustment, the cooling capacity and heating capacity should be multiplied by the correction factor 0.9;
8. The specifications may be changed due to product improvement without a prior notice. The parameters indicated on the unit nameplate should prevail.

## Ceiling Concealed FCU (3+1 Rows)

Model: ACR		200J	300J	400J	500J	600J	700J	800J	1000J	1200J	1400J	
Rated Air Flow (m <sup>3</sup> /h)	High	340	500	680	830	1000	1140	1340	1700	2040	2380	
	Medium	270	380	510	620	750	880	1030	1290	1540	1975	
	Low	190	240	340	420	560	610	720	890	1040	1255	
Cooling Capacity (W)	High	2210	3200	4150	4800	5950	6800	7900	9200	10275	12600	
	Medium	1890	2782	3570	4150	5200	5900	6900	8000	8500	11000	
	Low	1500	2304	2950	3400	4200	5000	5800	6700	7450	9500	
Sensible Cooling Capacity (W)	High	1590	2285	2880	3400	4200	4700	5750	6600	7400	9400	
	Medium	1350	1920	2420	2880	3570	3900	4800	5500	6200	7900	
	Low	1050	1555	1930	2210	2900	3200	3700	4200	4930	6200	
Heating Capacity (60/50°C) (W)		High	2050	3000	3850	4500	5200	6300	7550	8400	10800	
Heating Capacity (45/40°C) (W)		High	1300	1800	2300	2700	3200	3700	4500	5100	6600	
Power Input (W)	Low Static Pressure (12Pa)	High	30	45	55	72	93	100	128	147	183	221
		Medium	27	36	43	58	80	97	112	130	165	198
		Low	23	30	35	48	68	78	95	110	136	165
	30 Pa	High	38	55	65	82	100	120	148	169	206	245
		Medium	32	45	50	64	80	105	133	160	195	230
		Low	27	33	37	53	70	90	128	140	170	195
	50 Pa	High	45	64	75	91	114	130	165	200	243	290
		Medium	36	50	65	86	105	110	150	190	230	270
		Low	30	42	55	73	90	96	122	170	200	250
FCEER	Low Static Pressure (12Pa)	High	66	63	66	59	55	58	53	54	49	49
	30 Pa	High	53	53	57	52	52	50	47	48	44	45
	50 Pa	High	45	46	50	48	46	46	43	41	38	38
FCCOP (Water Inlet: 60°C)	Low Static Pressure (12Pa)	High	67	65	67	59	54	61	56	55	51	46
	30 Pa	High	53	54	57	52	51	51	49	48	45	42
	50 Pa	High	45	46	50	47	45	47	44	41	39	36
FCCOP (Water Inlet: 45°C)	Low Static Pressure (12Pa)	High	42	39	39	35	33	35	32	33	31	27
	30 Pa	High	33	32	33	31	31	29	28	29	28	25
	50 Pa	High	28	27	29	28	27	27	26	25	24	21
Sound Level (dB(A))	Low Static Pressure (12Pa)	High	36.5	38	39	42	45	46	46	47	49	51
		Medium	30	30	31	33	38	41	41	41	44	47
		Low	21	21	22	25	29	32	32	33	34	36
	30 Pa	High	38.5	41	42.5	45	46.5	48	47	49	51	52.5
		Medium	32	32.5	34	37.5	39	42	41	43	46	48
		Low	23	23	24	28.5	30	33	32	34	35.5	37
	50 Pa	High	42	43.5	45	47	49	50	50	52	53	53.5
		Medium	36	37	38	39.5	41	45	45	46.5	47.5	50
		Low	29	29	30	30	32	36	36	38	41	43
Sound Level* (dB(A))	30 Pa	High	37	39	40	43	44	46	46	47	49	50.5
		Medium	30	31	32	36	37	41	40	41	45	46
		Low	22.5	22	23	27	28	32	31	32	35	36
	50 Pa	High	40	41.5	43	45	47	48	48	49	51	51.5
		Medium	34	35	36	37	40	43	43	45	46	48
		Low	27	27	27.5	28	31	34	34	37	40	41
Fan	Type	Forward-curved multi-blade double inlet centrifugal fan										
Motor	Type	Single-phase capacitor motor										
Heat Exchanger	Structure Type	Efficient double-flanged aluminum fins and copper tubes, expanded into one										
	Maximum Operating Pressure (MPa)	1.6										
	Water Inlet/Outlet Pipe Diameter	Rc3/4 (Taper Pipe Female Threaded)										
Water Flow	Cooling Mode (m <sup>3</sup> /h)	0.39	0.63	0.73	0.86	1.04	1.17	1.39	1.65	1.9	2.04	
	Heating Mode (60/50°C) (m <sup>3</sup> /h)	0.21	0.29	0.33	0.42	0.47	0.55	0.66	0.72	0.88	0.95	
	Heating Mode (45/40°C) (m <sup>3</sup> /h)	0.22	0.31	0.41	0.47	0.53	0.63	0.76	0.86	1.04	1.13	
Water Resistance	Cooling Mode (kPa)	25	25	30	30	40	40	40	40	40	50	
	Heating Mode (60/50°C) (kPa)	10	10	20	25	15	20	30	20	30	35	
	Heating Mode (45/40°C) (kPa)	10	15	25	30	20	25	40	25	40	50	
Drain Pan	Condensate Water Pipe Diameter	Rc3/4 (Taper Pipe Male Threaded)										
Dimensions (Without Return Air Plenum)	Length (mm)	695	845	930	995	1085	1235	1530	1530	1795	1795	
	Width (mm)	470	470	470	470	470	470	470	470	490	490	
	Height (mm)	230	230	230	230	230	230	230	230	250	250	
Net weight	Air Return Plenum (Excluded) (kg)	11.5	13.5	15.5	17	19	20	24	27	33	35	
	Air Return Plenum (Included) (kg)	13.5	16.5	18.5	20	22	24	28	31	39	41	

★ Note:

- Cooling: supply water and return water temperatures 7/12°C; the dry/wet bulb temperature of air inlet is 27/19.5°C;
- Heating: supply water is 60°C or 45°C, water quantity being the same as during cooling; air return conditions: the dry bulb temperature of air inlet is 21°C;
- In the table, low static pressure indicates the air outlet static pressure at 0Pa (with air outlet and filter) and at 12Pa (without air outlet and filter);
- The air flow in the table is obtained when the unit is running in dry state and the dry bulb temperature of air inlet is 20°C;
- In the table, noise is measured according to Figure C.2 in GB/T 19232-2019 in a semi-anechoic room where the background noise is 11.5 dB(A);
- In the table, noise is measured according to GB/T 19232-2019 in a semi-anechoic room where the background noise is 11.5 dB(A);
- Left & right swing manner can be adjusted on site. After adjustment, the cooling capacity and heating capacity should be multiplied by the correction factor 0.9;
- The specifications may be changed due to product improvement without a prior notice. The parameters indicated on the unit nameplate should prevail.

## Ceiling Concealed FCU (Large Temperature Difference, 3 Rows)

Model: ACR		200J	300J	400J	500J	600J	700J	800J	1000J	1200J	1400J	
Rated Air Flow (m³/h)	High	340	510	680	850	1020	1190	1360	1700	2040	2380	
	Medium	270	380	510	640	780	880	1030	1290	1540	1850	
	Low	190	280	340	450	560	610	740	890	1040	1255	
Cooling Capacity (W)	High	2200	3100	4000	4800	5750	6500	8000	9100	11250	12800	
	Medium	1900	2700	3500	4100	5000	5500	6800	8200	9600	11000	
	Low	1600	2250	2900	3200	4000	4500	5700	6700	7400	7500	
Sensible Cooling Capacity (W)	High	1500	2200	2800	3500	4100	4700	5800	6700	8200	9700	
	Medium	1400	1900	2400	2900	3500	3900	4800	5700	6900	8200	
	Low	1050	1500	1900	2200	2800	3200	3900	4500	5100	5900	
Heating Capacity (60/50°C) (W)		High	3400	4850	6100	7500	9000	10200	12300	14500	19900	
Heating Capacity (45/40°C) (W)		High	2100	3000	3850	4600	5500	6300	7700	8800	10800	
Power Input (W)	Low Static Pressure (12Pa)	High	30	45	55	72	93	100	128	147	183	221
		Medium	27	36	43	58	80	97	112	130	165	198
		Low	23	30	35	48	68	78	95	110	136	165
	30 Pa	High	38	55	65	82	100	120	148	169	206	245
		Medium	32	45	50	64	80	105	133	160	195	230
		Low	27	33	37	53	70	90	128	140	170	195
	50 Pa	High	45	64	75	91	114	130	165	200	243	290
		Medium	36	50	65	86	105	110	150	190	230	270
		Low	30	42	55	73	90	96	122	170	200	250
FCEER	Low Static Pressure (12Pa)	High	68	65	67	63	56	60	58	56	53	
	30 Pa	High	55	53	57	55	53	51	51	50	48	
	50 Pa	High	47	46	50	50	47	47	46	42	41	
FCCOP (Water Inlet: 60°C)	Low Static Pressure (12Pa)	High	106	101	102	98	88	95	90	90	87	
	30 Pa	High	85	84	87	87	83	80	78	79	75	
	50 Pa	High	72	72	76	78	73	74	71	68	64	
FCCOP (Water Inlet: 45°C)	Low Static Pressure (12Pa)	High	65	62	64	60	54	58	56	54	51	
	30 Pa	High	52	52	55	53	50	49	49	48	46	
	50 Pa	High	44	45	48	48	45	46	44	41	40	
Sound Level (dB(A))	Low Static Pressure (12Pa)	High	35	38	39	41	45	46	46	47	49	51
		Medium	28.5	30	31	32	37	40	40	41	44	47
		Low	20.5	21	22	24	28	31	31	32	34	35
	30 Pa	High	38	41	42.5	45	46.5	48	47	49	51	52
		Medium	30.5	32	34	36.5	38.5	41	41	43	46	48
		Low	23	22	22	27.5	30	32	32	34	35	36
	50 Pa	High	42	43	45	47	49	50	50	52	53	53
		Medium	35.5	36	38	38.5	40	44	44	46	47.5	49
		Low	29	28	28	29	31	36	36	38	40	42
Sound Level* (dB(A))	30 Pa	High	36	39	40	43	44	46	46	47	49	50
		Medium	29	30	32	35	36	40	40	41	45	46
		Low	22	21	21	26	27	31	31	32	34	35
	50 Pa	High	40	41	43	45	47	48	48	49	51	51
		Medium	33.5	34	36	36.5	39	42	42	45	46	47
		Low	27	26	26	27	30	34	34	37	39	40
Fan	Type	Forward-curved multi-blade double inlet centrifugal fan										
Motor	Type	Single-phase capacitor motor										
Heat Exchanger	Maximum Operating Pressure (MPa)	Efficient double-flanged aluminum fins and copper tubes, expanded into one										
	Water Inlet/Outlet Pipe Diameter	1.6										
	Water Inlet/Outlet Pipe Diameter	Rc3/4 (Taper Pipe Female Threaded)										
Water Flow m³/h		0.24	0.33	0.45	0.5	0.61	0.7	0.83	0.99	1.2	1.42	
Water Resistance	kPa	25	25	30	25	40	30	30	40	40	40	
Drain Pan	Condensate Water Pipe Diameter	Rc3/4 (Taper Pipe Male Threaded)										
Dimensions (Without Return Air Plenum)	Length (mm)	695	845	930	995	1085	1235	1530	1530	1795	1795	
	Width (mm)	470	470	470	470	470	470	470	470	490	490	
	Height (mm)	230	230	230	230	230	230	230	230	250	250	
Net weight	Air Return Plenum (Excluded) (kg)	10.5	12.5	14.5	16	17	18.5	22	25	30	31.5	
	Air Return Plenum (Included) (kg)	12.5	15.5	17.5	19	20	22.5	26	29	36	37.5	

★ Note:

1. Cooling: supply water and return water temperatures 5/13°C; the dry/wet bulb temperature of air inlet is 27/19.5°C;
2. Heating: supply water is 60°C or 45°C, water quantity being the same as during cooling; air return conditions: the dry bulb temperature of air inlet is 21°C;
3. In the table, low static pressure indicates the air outlet static pressure at 0Pa (with air outlet and filter) and at 12Pa (without air outlet and filter);
4. The air flow in the table is obtained when the unit is running in dry state and the dry bulb temperature of air inlet is 20°C;
5. In the table, noise is measured according to Figure C.2 in GB/T 19232-2019 in a semi-anechoic room where the background noise is 11.5 dB(A);
6. In the table, noise is measured according to GB/T 19232-2019 in a semi-anechoic room where the background noise is 11.5 dB(A);
7. Left & right swing manner can be adjusted on site. After adjustment, the cooling capacity and heating capacity should be multiplied by the correction factor 0.9;
8. The specifications may be changed due to product improvement without a prior notice. The parameters indicated on the unit nameplate should prevail.

## Ceiling Concealed FCU (Large Temperature Difference, 3+1 Rows)

Model: ACR		200J	300J	400J	500J	600J	700J	800J	1000J	1200J	1400J	
Rated Air Flow (m <sup>3</sup> /h)	High	340	500	680	830	1000	1140	1340	1700	2040	2380	
	Medium	270	380	510	620	750	880	1030	1290	1540	1975	
	Low	190	240	340	420	560	610	720	890	1040	1255	
Cooling Capacity (W)	High	2200	3100	4000	4800	5750	6500	8000	9100	11250	12800	
	Medium	1900	2700	3500	4100	5000	5500	6800	8200	9600	11000	
	Low	1600	2250	2900	3200	4000	4500	5700	6700	7400	7500	
Sensible Cooling Capacity (W)	High	1500	2200	2800	3500	4100	4700	5800	6700	8200	9700	
	Medium	1400	1900	2400	2900	3500	3900	4800	5700	6900	8200	
	Low	1050	1500	1900	2200	2800	3200	3900	4500	5100	5900	
Heating Capacity (60/50°C) (W)	High	2050	3000	3850	4500	5200	6300	7550	8400	9800	10800	
Heating Capacity (45/40°C) (W)	High	1300	1800	2300	2700	3200	3700	4500	5100	6100	6600	
Power Input (W)	Low Static Pressure (12Pa)	High	30	45	55	72	93	100	128	147	183	221
		Medium	27	36	43	58	80	97	112	130	165	198
		Low	23	30	35	48	68	78	95	110	136	165
	30 Pa	High	38	55	65	82	100	120	148	169	206	245
		Medium	32	45	50	64	80	105	133	160	195	230
		Low	27	33	37	53	70	90	128	140	170	195
	50 Pa	High	45	64	75	91	114	130	165	200	243	290
		Medium	36	50	65	86	105	110	150	190	230	270
		Low	30	42	55	73	90	96	122	170	200	250
FCEER	Low Static Pressure (12Pa)	High	68	65	67	63	56	60	58	56	56	53
	30 Pa	High	55	53	57	55	53	51	51	50	50	48
	50 Pa	High	47	46	50	50	47	47	46	42	43	41
FCCOP (Water Inlet: 60°C)	Low Static Pressure (12Pa)	High	67	65	67	59	54	61	56	55	51	46
	30 Pa	High	53	54	57	52	51	51	49	48	45	42
	50 Pa	High	45	46	50	47	45	47	44	41	39	36
FCCOP (Water Inlet: 45°C)	Low Static Pressure (12Pa)	High	42	39	39	35	33	35	32	33	31	27
	30 Pa	High	33	32	33	31	31	29	28	29	28	25
	50 Pa	High	28	27	29	28	27	27	26	25	24	21
Sound Level (dB(A))	Low Static Pressure (12Pa)	High	36.5	38	39	42	45	46	46	47	49	51
		Medium	30	30	31	33	38	41	41	41	44	47
		Low	21	21	22	25	29	32	32	33	34	36
	30 Pa	High	38.5	41	42.5	45	46.5	48	47	49	51	52.5
		Medium	32	32.5	34	37.5	39	42	41	43	46	48
		Low	23	23	24	28.5	30	33	32	34	35.5	37
	50 Pa	High	42	43.5	45	47	49	50	50	52	53	53.5
		Medium	36	37	38	39.5	41	45	45	46.5	47.5	50
		Low	29	29	30	30	32	36	36	38	41	43
Sound Level* (dB(A))	30 Pa	High	37	39	40	43	44	46	46	47	49	50.5
		Medium	30	31	32	36	37	41	40	41	45	46
		Low	22.5	22	23	27	28	32	31	32	35	36
	50 Pa	High	40	41.5	43	45	47	48	48	49	51	51.5
		Medium	34	35	36	37	40	43	43	45	46	48
		Low	27	27	27.5	28	31	34	34	37	40	41
Fan	Type	Forward-curved multi-blade double inlet centrifugal fan										
Motor	Type	Single-phase capacitor motor										
Heat Exchanger	Structure Type	Efficient double-flanged aluminum fins and copper tubes, expanded into one										
	Maximum Operating Pressure (MPa)	1.6										
	Water Inlet/Outlet Pipe Diameter	Rc3/4 (Taper Pipe Female Threaded)										
Water Flow	Cooling Mode (m <sup>3</sup> /h)	0.24	0.33	0.45	0.5	0.61	0.7	0.83	0.99	1.2	1.42	
	Heating Mode (60/50°C) (m <sup>3</sup> /h)	0.21	0.29	0.33	0.42	0.47	0.55	0.66	0.72	0.88	0.95	
	Heating Mode (45/40°C) (m <sup>3</sup> /h)	0.22	0.31	0.41	0.47	0.53	0.63	0.76	0.86	1.04	1.13	
Water Resistance	Cooling Mode (kPa)	25	25	30	25	40	30	30	40	40	40	
	Heating Mode (60/50°C) (kPa)	10	10	20	25	15	20	30	20	30	35	
	Heating Mode (45/40°C) (kPa)	10	15	25	30	20	25	40	25	40	50	
Drain Pan	Condensate Water Pipe Diameter	Rc3/4 (Taper Pipe Male Threaded)										
Dimensions (Without Return Air Plenum)	Length (mm)	695	845	930	995	1085	1235	1530	1530	1795	1795	
	Width (mm)	470	470	470	470	470	470	470	470	490	490	
Net Weight	Height (mm)	230	230	230	230	230	230	230	230	250	250	
	Air Return Plenum (Excluded) (kg)	11.5	13.5	15.5	17	19	20	24	27	33	35	
	Air Return Plenum (Included) (kg)	13.5	16.5	18.5	20	22	24	28	31	39	41	

★ Note:

- Cooling: supply water and return water temperatures 5/13°C; the dry/wet bulb temperature of air inlet is 27/19.5°C;
- Heating: supply water and return water temperatures 60/50°C or 45/40°C; air return conditions: the dry bulb temperature of air inlet is 21°C;
- In the table, low static pressure indicates the air outlet static pressure at 0Pa (with air outlet and filter) and at 12Pa (without air outlet and filter);
- The air flow in the table is obtained when the unit is running in dry state and the dry bulb temperature of air inlet is 20°C;
- In the table, noise is measured according to Figure C.2 in GB/T 19232-2019 in a semi-anechoic room where the background noise is 11.5 dB(A);
- In the table, noise is measured according to GB/T 19232-2019 in a semi-anechoic room where the background noise is 11.5 dB(A);
- For a 4-pipe unit, there are 3 rows of cooling coils and 1 row of heating coil;
- The specifications may be changed due to product improvement without a prior notice. The parameters indicated on the unit nameplate should prevail.



## Dimension

### Ceiling Concealed FCU (3 Rows/Large Temperature Difference, 3 Rows)

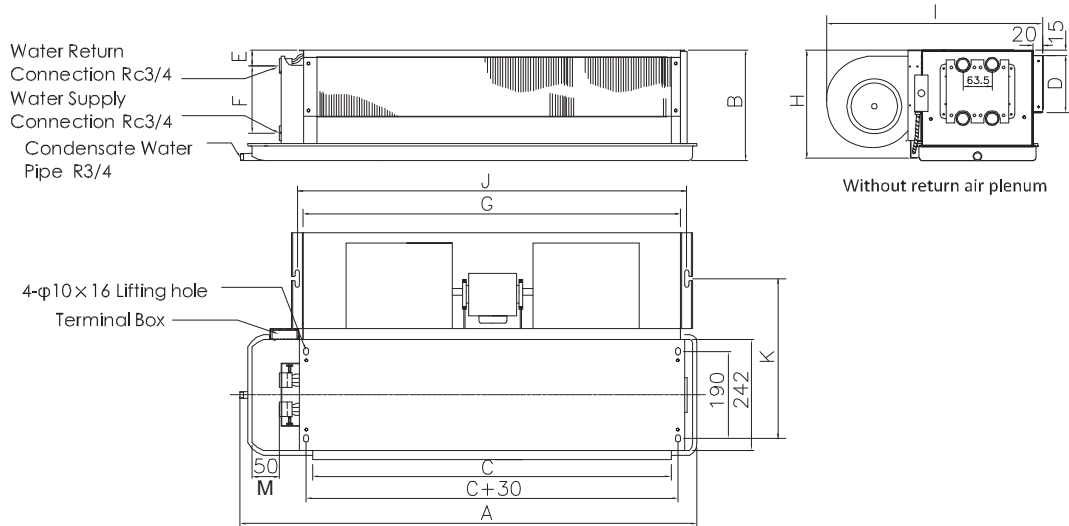

ACR	A	B	C	D	E	F	G	H	I	J	K	M	Motor Quantity	Fan Quantity
200	695	230	435	135	54	118	477	225	470	504	346	50	1	1
300	845	230	570	135	54	118	610	225	470	637	346	65	1	2
400	930	230	670	135	54	118	712	225	470	739	346	50	1	2
500	995	230	730	135	54	118	772	225	470	799	346	55	1	2
600	1085	230	825	135	54	118	867	225	470	894	346	50	1	2
700	1235	230	970	135	54	118	1012	225	470	1039	346	55	1	2
800	1530	230	1215	135	54	118	1257	225	470	1284	346	105	1	3
1000	1530	230	1255	135	54	118	1297	225	470	1324	346	65	2	3
1200	1795	250	1510	135	54	118	1552	240	490	1579	357	45	2	4
1400	1795	250	1510	135	54	118	1552	240	490	1579	357	45	2	4

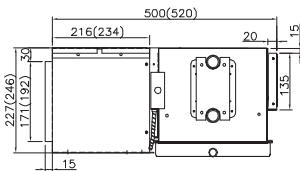

With back return air plenum (TCR200-1200)  
Dimensions in brackets for TCR1200

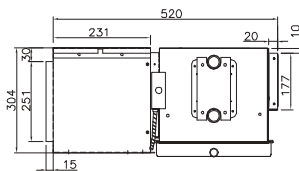

With back return air plenum (TCR1400)

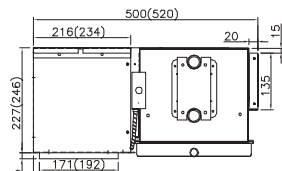

With bottom return air plenum (TCR200-1200)  
Dimensions in brackets for TCR1200

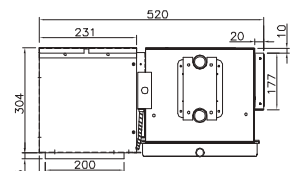

With bottom return air plenum (TCR1400)

ACR	Length of return air plenum	Length of plenum wind-gap
200	483.6	422
300	615.6	557
400	725.6	657
500	775.6	717
600	870.6	812
700	1015.6	957
800	1260.6	1202
1000	1300.6	1242
1200	1555.6	1497
1400	1634	1596

# Ceiling Concealed FCU (3+1 Rows/Large Temperature Difference, 3+1 Rows)

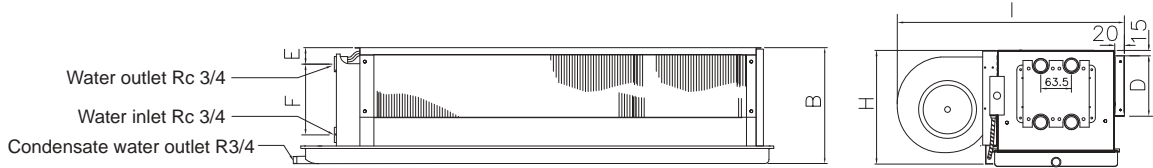

Side view of the unit without an air return plenum

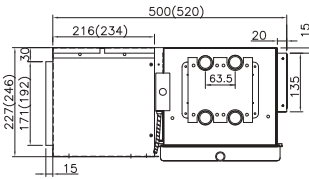
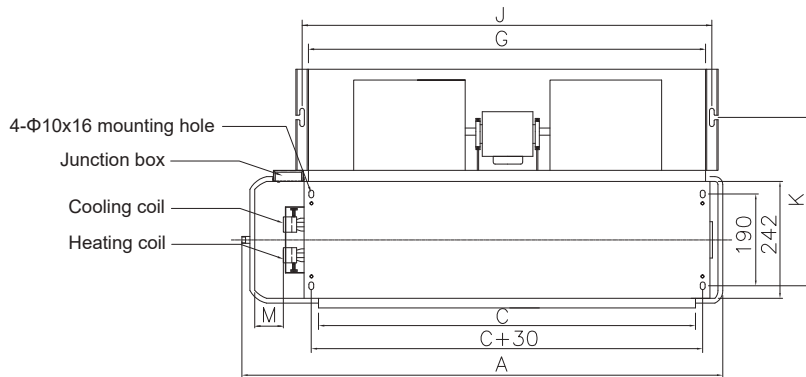

Side view of the unit with a rear air return plenum (models 200-1200)  
Side view of the unit with a rear air return plenum (model 1400)

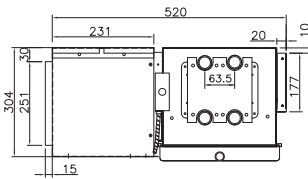

Side view of the unit with a rear air return plenum (models 1400)

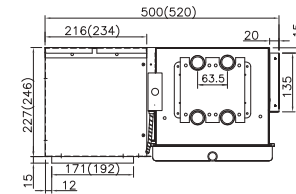

Side view of the unit with a bottom air return plenum (models 200-1200) (Dimensions in brackets are dimensions of model 1200)

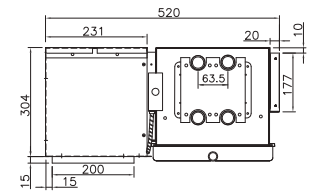

Side view of the unit with a bottom air return plenum (model 1400)

Model: ACR	A	B	C	D	E	F	G	H	I	J	K	M
200	695	230	435	135	54	118	477	225	470	504	346	50
300	845	230	570	135	54	118	610	225	470	637	346	65
400	930	230	670	135	54	118	712	225	470	739	346	50
500	995	230	730	135	54	118	772	225	470	799	346	55
600	1085	230	825	135	54	118	867	225	470	894	346	50
700	1235	230	970	135	54	118	1012	225	470	1039	346	55
800	1530	230	1215	135	54	118	1257	225	470	1284	346	105
1000	1530	230	1255	135	54	118	1297	225	470	1324	346	65
1200	1795	250	1510	135	54	118	1552	240	490	1579	357	45
1400	1795	250	1510	135	54	118	1552	240	490	1579	357	45

★ **Note:**

1. The air return plenum unit with a filter screen does not have an air return flange only, with other dimensions remaining the same.
2. When vibration-absorbing lifting hooks are used for lifting the unit, tell the factory about it.



ARQ 300 C L3SDNNTY

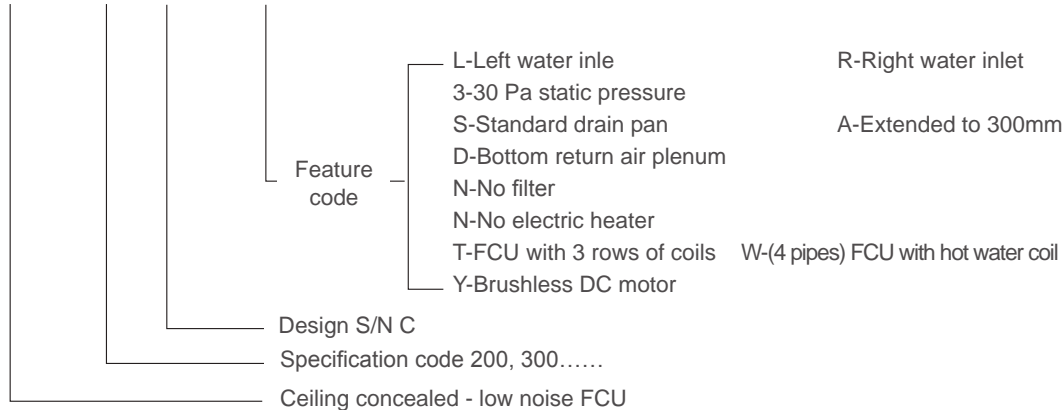

Remarks: The standard default static pressure of the ARQ unit is 30 Pa, while, 12 Pa and 50 Pa static pressure can be adjusted on site.

## 1. Low Noise

- It adopts the stamping-formed wide impeller with imported hot dip galvanized steel sheet of high quality and the centrifugal (blade: forward-curved) fan of low speed, and features low noise, high efficiency and exquisite structure.
- It adopts the high quality rolling bearings with low noises and little vibration delivered by an international famous brand, which do not need to be maintained and can be used for a long time.
- It adopts the composite acoustical coating meeting environmental protection requirements. Anechoic layers with different interface shapes are provided between composite layers to improve the acoustic attenuation performance greatly.

### Main technologies

- Airtronics's independently patented micro-perforated panel diversion assembly
- Eco-friendly flame retardant and anechoic material used in the FCU cavity
- Combined with the high efficiency motor by matching the centrifugal (blade: forward-curved) fan

## 2. Brushless DC motor as optional

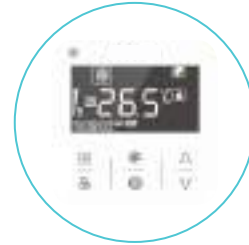
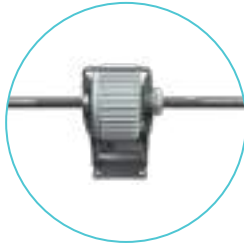

### High efficiency and energy saving

- Low heat radiation, efficiencies up to 75% (in contrast to the 30%-40% of conventional AC motor), average power consumptions equal to 50%-70% of AC motor.
- Optional solutions of three-stage speed regulation and stepless speed regulation; the air conditioner operates with a partial load in 90% of the time; under the stepless regulation mode, the motor speed is adjusted based on actual demand to save energy and substantially increase the energy efficiency.

### Low noise to ensure comfort

- Adopts the PWM sine wave control technology to achieve low vibration and noise; driver carrier frequency above 15k to eliminate high frequency noise and special groove type design to reduce low frequency noise.
- The output torque satisfies the load application characteristics of unit and keeps the unit in a highly stable status.

### A wide range of applications, reliable and safe

- The LCD thermostat is stylish and can be used as a high-end thermostat in various types of Airtronics fan coils. The operating voltage is a globally applicable 90 VAC to 230 VAC. It is used to control the opening/closing of the pipeline system control components such as the fan coil pipeline valves to turn on/off the circulation media such as the cold and hot water sources of the pipeline, thus controlling regional temperature.

### Intelligent control

- The thermostat with the RS485 interface is optional. It supports the Modbus communication protocol and can be used for linkage with the building automation system to implement the centralized operation management of remote automatic control and monitoring.
- The elegant thermostat is provided with an LCD screen to realize perfect fusion with building decoration.

## 3. Ultra-low noise, quiet and comfortable

- It adopts the forward curved centrifugal fan of low speed, and features low noise, high efficiency and exquisite structure. The motors use imported corrugated washers and advanced damping rotors with low vibration and noise.
- Combined with the high efficiency motor and the forward curved centrifugal fan, the unit is able to run quietly, thus greatly improving comfort.
- The unit's noise level is far below the national standard, reaching the industry leading level.

## 4. Compact, light, flexible and elegant

- The unit is compact in structure, lightweight and elegant in its entirety. The installation space is about 6% less than that of the standard fan coil. The ultra-thin design can meet the maximum requirements such as the effective floor height of the house.
- The return air plenum is equipped, which is installed on site.

## Low Noise DC Brushless FCU (3 Rows)

ARQ		300C	400C	500C	600C	700C	800C	1000C	1200C	
Rated Air Flow (m³/h)	High	510	680	850	1020	1190	1360	1700	2040	
	Medium	380	510	640	765	890	1020	1275	1530	
	Low	255	340	425	510	595	680	850	1020	
Cooling Capacity (W)	High	3200	4150	5000	5950	6600	8100	9100	11250	
	Medium	2782	3570	4197	5200	5600	6882	8200	9613	
	Low	2304	2950	3298	4200	4600	5749	6700	7403	
Sensible Cooling Capacity (W)	High	2285	2880	3570	4200	4700	5880	6700	8260	
	Medium	1920	2420	2930	3570	3900	4880	5700	6935	
	Low	1555	1930	2210	2900	3200	3935	4500	5120	
Heating Capacity (Water Inlet: 60°C) (W)	High	5200	6500	7870	9800	10900	13570	14900	18800	
Heating Capacity (Water Inlet: 45°C) (W)	High	3200	4150	5000	5950	6600	8100	9100	11250	
Power Input (W)	Low Static Pressure (12Pa)	High	17	24	34	47	47	54	72	99
		Medium	10	14	18	24	24	28	39	48
		Low	6	8	10	13	13	15	22	24
	30 Pa	High	23	33	44	57	57	68	90	119
		Medium	13	17	22	29	29	34	47	57
		Low	8	9	12	14	15	18	25	27
	50 Pa	High	31	42	53	68	71	87	111	143
		Medium	16	22	27	33	35	42	55	88
		Low	9	11	13	16	17	20	28	38
FCEER	Low Static Pressure (12Pa)	High	135	130	116	96	104	109	95	88
	30 Pa	High	108	101	94	83	90	92	80	76
	50 Pa	High	85	83	80	72	76	76	67	66
FCCOP (Water Inlet: 60°C)	Low Static Pressure (12Pa)	High	220	204	182	158	172	183	155	148
	30 Pa	High	175	159	148	136	149	154	131	128
	50 Pa	High	138	130	126	118	125	127	110	110
FCCOP (Water Inlet: 45°C)	Low Static Pressure (12Pa)	High	135	130	116	96	104	109	95	88
	30 Pa	High	108	101	94	83	90	92	80	76
	50 Pa	High	85	83	80	72	76	76	67	66
Sound Level (dB(A))	Low Static Pressure (12Pa)	High	33	37	40	43	43	43	45	47
		Medium	25	29	30	35	35	36	38	40
		Low	21	22	24	28	28	28	28	30
	30 Pa	High	38	40	43.5	45	45	45.5	47	49
		Medium	30	32	34.5	36	36	36.5	40	42
		Low	22	22	27	30	30	30	30	32
	50 Pa	High	41.5	43	45.5	47	47	48	49	51
		Medium	34	36	37	39	39	40	42	45
		Low	25	27	29	32	32	32	32	36
Sound Level* (dB(A))	30 Pa	High	36	38	42	43	43	43.5	45	47
		Medium	29	31	33	34	34	35	38	40
		Low	21	21	26	29	29	29	29	31
	50 Pa	High	40	41	43.5	45	45	46	47	49
		Medium	33	35	36	38	38	39	40	43
		Low	24	26	28	31	31	31	31	34
	Fan	Type	Forward-curved multi-blade double inlet centrifugal fan							
	Motor	Type	Brushless DC motor (embedded with AC-DC conversion)							
	Heat Exchanger	Structure Type	Efficient double-flanged aluminum fins and copper tubes, expanded into one							
Maximum Operating Pressure (MPa)		1.6								
Water Inlet/Outlet Pipe Diameter		Rc3/4 (Taper Pipe Female Threaded)								
Water Flow (m³/h)		0.6	0.71	0.83	1.02	1.1	1.36	1.61	1.91	
Water Resistance	kPa	30	30	30	40	40	40	40	40	
Drain Pan	Condensate Water Pipe Diameter	Rc3/4 (Taper Pipe Male Threaded)								
Dimensions	Length (mm)	890		1050		1430		1730		
	Width (mm)	465		465		465		485		
	Height (mm)	242		242		242		262		
Net Weight (kg)		15		17		24		32		

★ Note:

1. Cooling: supply water and return water temperatures 7/12°C; the dry/wet bulb temperature of air inlet is 27/19.5°C;
2. Heating: supply water is 60°C or 45°C, water quantity being the same as during cooling; air return conditions: the dry bulb temperature of air inlet is 21°C;
3. In the table, low static pressure indicates the air outlet static pressure at 0Pa (with air outlet and filter) and at 12Pa (without air outlet and filter);
4. The air flow in the table is obtained when the unit is running in dry state and the dry bulb temperature of air inlet is 20°C;
5. In the table, noise is measured according to Figure C.2 in GB/T 19232-2019 in a semi-anechoic room where the background noise is 11.5 dB(A);
6. In the table, noise is measured according to GB/T 19232-2019 in a semi-anechoic room where the background noise is 11.5 dB(A);
7. Left & right swing manner cannot be adjusted on site.
8. The specifications may be changed due to product improvement without a prior notice. The parameters indicated on the unit nameplate should prevail.

## Low Noise DC Brushless FCU (3+1 rows 4 pipes)

ARQ		300C	400C	500C	600C	700C	800C	1000C	1200C	
Rated Air Flow (m <sup>3</sup> /h)	High	500	650	830	1000	1120	1300	1600	1900	
	Medium	360	480	620	740	840	960	1180	1340	
	Low	240	320	425	500	590	680	780	880	
Cooling Capacity (W)	High	3100	4000	4850	5600	6200	7800	9000	10800	
	Medium	2480	3200	3880	4480	4960	6240	7200	8640	
	Low	1860	2400	2910	3360	3720	4680	5400	6480	
Sensible Cooling Capacity (W)	High	2170	2800	3395	3920	4340	5460	6300	7560	
	Medium	1736	2240	2716	3136	3472	4368	5040	6048	
	Low	1302	1680	2037	2352	2604	3276	3780	4536	
Heating Capacity (Water Inlet: 60°C) (W)		High	2800	3600	4400	5000	5600	7000	8100	9800
Heating Capacity (Water Inlet: 45°C) (W)		High	1800	2300	2700	3200	3700	4500	5100	6100
Power Input (W)	Low Static Pressure (12Pa)	High	19	25	38	50	65	74	88	100
		Medium	12	15	21	27	32	36	47	55
		Low	8	9	11	14	16	20	22	26
	30 Pa	High	27	34	50	62	71	81	101	122
		Medium	15	19	26	33	38	44	56	64
		Low	9	10	13	16	18	23	26	29
	50 Pa	High	35	45	61	77	89	100	125	148
		Medium	19	24	32	40	46	54	65	75
		Low	11	12	15	19	20	26	29	33
FCEER	Low Static Pressure (12Pa)	High	123	121	102	85	76	82	80	84
	30 Pa	High	94	95	81	72	71	77	72	72
	50 Pa	High	75	75	69	61	59	65	60	61
FCCOP (Water Inlet: 60°C)	Low Static Pressure (12Pa)	High	135	127	104	89	80	84	82	87
	30 Pa	High	97	96	81	73	73	78	73	73
	50 Pa	High	76	74	67	60	59	64	60	61
FCCOP (Water Inlet: 45°C)	Low Static Pressure (12Pa)	High	85	79	62	55	49	53	50	53
	30 Pa	High	61	60	49	46	46	49	44	44
	50 Pa	High	48	47	41	38	37	41	37	37
Sound Level (dB(A))	Low Static Pressure (12Pa)	High	33	38	41	44	44	44	45	47
		Medium	27	31	34	38	38	38	38	40
		Low	23	24	27	28	28	28	28	32
	30 Pa	High	38	41	44	47	47	47	47	49
		Medium	32	34	35	40	40	40	40	42
		Low	25	26	29	31	31	31	32	32
	50 Pa	High	41.5	43	46.5	48	48	48.5	49	51
		Medium	34	36	37	41	41	41	42	45
		Low	26	28	30	33	33	33	34	36
Sound Level* (dB(A))	30 Pa	High	36	39	42	45	45	45	45	47
		Medium	31	32	34	39	39	39	39	41
		Low	24	25	28	30	30	30	30	31
	50 Pa	High	40	41	45	46	46	47	47	49
		Medium	33	35	36	40	40	40	41	43
		Low	25	27	29	32	32	32	33	35
	Fan	Type	Forward-curved multi-blade double inlet centrifugal fan							
	Motor	Type	Brushless DC motor (embedded with AC-DC conversion)							
	Heat Exchanger	Structure Type	Efficient double-flanged aluminum fins and copper tubes, expanded into one							
Maximum Operating Pressure (MPa)		1.6								
Water Inlet/Outlet Pipe Diameter		Rc3/4 (Taper Pipe Female Threaded)								
Water Flow	Cooling Mode (m <sup>3</sup> /h)	0.55	0.72	0.87	1.05	1.12	1.39	1.67	1.90	
	Heating Mode (60/50°C) (m <sup>3</sup> /h)	0.24	0.31	0.38	0.43	0.48	0.60	0.69	0.84	
	Heating Mode (45/40°C) (m <sup>3</sup> /h)	0.31	0.38	0.49	0.55	0.67	0.75	0.93	1.06	
Water Resistance	Cooling Mode (kPa)	30	30	30	40	40	40	40	40	
	Heating Mode (60/50°C) (kPa)	20	30	30	40	30	40	40	40	
	Heating Mode (45/40°C) (kPa)	20	30	30	40	40	40	40	40	
Drain Pan	Condensate Water Pipe Diameter	Rc3/4 (Taper Pipe Male Threaded)								
Dimensions	Length (mm)	890			1050		1430		1730	
	Width (mm)	465			465		465		485	
	Height (mm)	242			242		242		262	
Net Weight (kg)		18		21		29		38		

★ Note:

- Cooling: supply water and return water temperatures 7/12°C; the dry/wet bulb temperature of air inlet is 27/19.5°C;
- Heating: supply water and return water temperatures 60/50°C or 45/40°C; air return conditions: the dry bulb temperature of air inlet is 21°C;
- In the table, low static pressure indicates the air outlet static pressure at 0Pa (with air outlet and filter) and at 12Pa (without air outlet and filter);
- The air flow in the table is obtained when the unit is running in dry state and the dry bulb temperature of air inlet is 20°C;
- In the table, noise is measured according to Figure C.2 in GB/T 19232-2019 in a semi-anechoic room where the background noise is 11.5 dB(A);
- In the table, noise is measured according to GB/T 19232-2019 in a semi-anechoic room where the background noise is 11.5 dB(A);
- Left & right swing manner cannot be adjusted on site.
- For a 4-pipe unit, there are 3 rows of cooling coils and 1 row of heating coil;
- The specifications may be changed due to product improvement without a prior notice. The parameters indicated on the unit nameplate should prevail.

## Dimension

### Low Noise DC Brushless FCU (Two Pipes & Four Pipes)

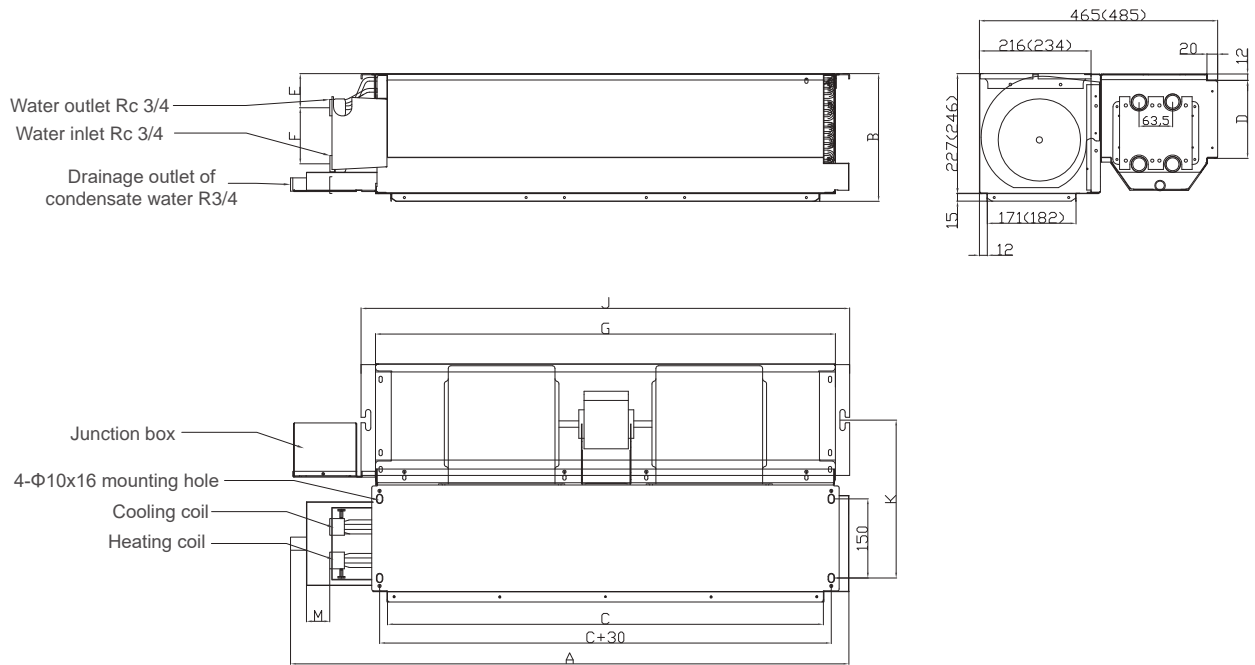

ARQ	A	B	C	D	E	F	G	J	K	M
300C	890	242	665	150	54	118	712	739	300	45
400C	890	242	665	150	54	118	712	739	300	45
500C	1050	242	825	150	54	118	867	894	300	45
600C	1050	242	825	150	54	118	867	894	300	45
700C	1430	242	1205	150	54	118	1257	1284	300	45
800C	1430	242	1205	150	54	118	1257	1284	300	45
1000C	1730	261	1505	150	54	118	1552	1579	312	45
1200C	1730	261	1505	150	54	118	1552	1579	312	45

**Note:**

1. The unit with return air plenum does not have a return air flange, with other dimensions remaining the same.
2. When vibration-absorbing lifting hooks are used for lifting the unit, tell the factory about it.

**CEILING CONCEALED  
HIGH PRESSURE FCU - AFM**



AFM 800 B LHSDNN

Feature  
code

- L-Left water inlet
- H-High static pressure
- S-Standard drain pan
- D-Bottom return air plenum
- N-No filter
- N-No electric heater

R-Right water inlet

B-Back return air plenum  
A-Nylon filter

Design S/N A, B, C

Specification code 800, 1200.....

High air flow FCU



## AFM Ceiling Concealed High Pressure FCU

Model AFM		800B	1000B	1200B	1600B	1800B	2000B	3000B
Rated Air Flow (m <sup>3</sup> /h)	High	1265	1510	1925	2490	2945	3880	5500
	Medium	1015	1215	1540	1990	2360	3100	4395
	Low	815	970	1230	1595	1890	2485	3520
Air Outlet Static Pressure (Pa)	High	130	130	130	130	130	130	130
Cooling Capacity (kW)	High	8.29	9.87	12.04	15.93	19.11	24.26	34.41
	Medium	6.64	7.90	9.63	12.75	15.29	19.39	27.51
	Low	5.30	6.31	7.70	10.20	12.22	15.53	22.01
Sensible Cooling Capacity (kW)	High	6.11	7.39	8.75	11.87	14.28	17.62	25.00
	Medium	4.89	5.91	6.99	9.51	11.42	14.09	19.98
	Low	3.92	4.73	5.60	7.61	9.14	11.29	15.99
Heating Capacity (kW)	High	12.37	15.19	19.60	24.56	28.66	39.47	55.99
	Medium	9.89	12.51	15.68	19.65	22.93	31.58	44.79
	Low	7.91	9.72	12.54	15.73	18.34	25.29	35.84
Power Input (W)	High	280	370	600	700	750	1200	1800
Sound Pressure Level (dB(A))	High	62	63	64	63	64.5	65	66
Fan	Type	Forward-curved multi-blade centrifugal fan (galvanized steel sheet)						
	Qty	1	1	1	2	2	2	3
Motor	Type	Single-phase capacitor motor						
	Insulation Class	B						
	Power Supply	220V~50Hz						
	Qty	1	1	1	1	2	2	3
Heat Exchanger	Structure Type	Aluminum-finned and copper-tube, mechanical expanding						
	Maximum Operating Pressure (MPa)	1.6MPa						
	Water Inlet/Outlet Pipe Diameter	R1 (taper pipe male threaded)					R1 <sup>1/2</sup> (taper pipe male threaded)	
	Water Flow (m <sup>3</sup> /h)	1.60	1.88	2.39	3.08	3.65	4.50	6.16
Water Pressure Drop (kPa)		6	14	25	20	25	35	45
Drain pan	Condensate Water Pipe Diameter	R1 (taper pipe male threaded)						
Dimensions	Length (mm)	860	860	960	1110	1260	1560	2010
	Width (mm)	820	820	820	820	820	820	820
	Height (mm)	430	430	430	430	430	430	430
Net Weight (kg)		50	50	56	65	76	94	126

### Note:

- Cooling capacity test conditions: supply water and return water temperatures 7/12°C; air return conditions: the dry/wet bulb temperature of air inlet is 27°C;
- Heating capacity test conditions: supply water is 60°C, water quantity being the same as during cooling capacity test; air return conditions: the dry bulb temperature of air inlet is 21°C;
- The air flow in the table is obtained when the unit is running in dry state and the dry bulb temperature is 20°C;
- When FCU residual pressure consumption is 80Pa, moisture might occur;
- Unless specified otherwise, the unit comes with the following return air plenum;
- The sound pressure level in the table is obtained in a semi-anechoic chamber with noise at 11.5dB(A);
- The specifications may be changed due to product improvement without a prior notice. The parameters indicated on the unit nameplate should prevail;
- If thermostat or three-speed switch is required, please consult the factory.

## Dimension

### Ceiling Concealed - High Pressure FCU

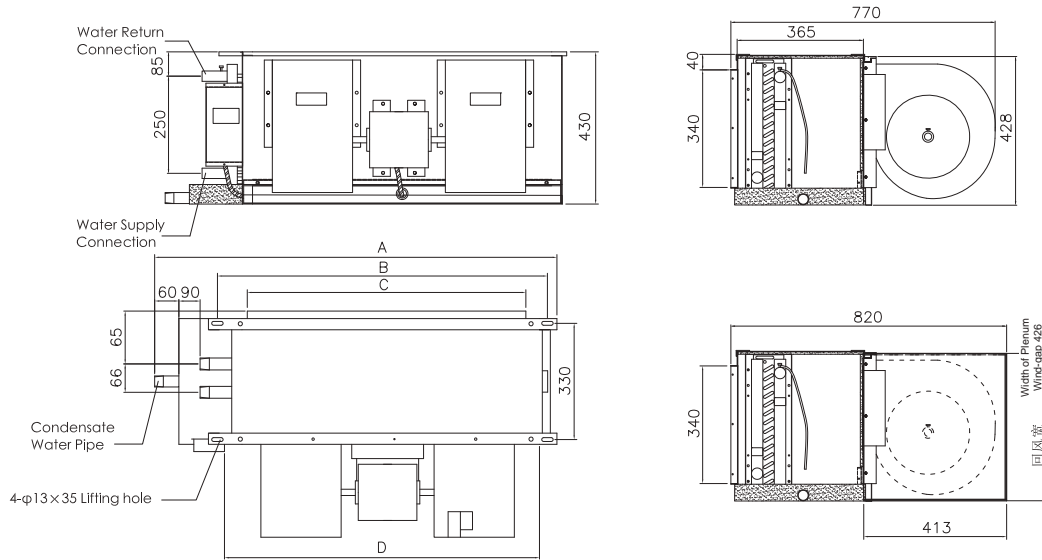

Model AFM	A	B	C	D	Inlet/outlet Pipe	Condensate Water Pipe	Motor Quantity (S/H)	Fan Quantity
800B	860	683	530	653	R1	R1	1/1	1
1000B	860	683	530	653	R1	R1	1/1	1
1200B	960	783	630	653	R1	R1	1/1	1
1600B	1110	953	800	753	R1	R1	1/1	2
1800B	1260	1083	930	923	R1	R1	1/2	2
2000B	1560	1403	1250	1373	R1 <sup>1/2</sup>	R1	2/2	2
3000B	2010	1853	1700	1823	R1 <sup>1/2</sup>	R1	3/3	3



**Characteristics:**

- 360° air outlet, no blind spot.
- Low noise  
The quality heat insulating and anechoic material is used to minimize the unit vibration and noise. The 3D aerofoil-type blade fan with a large diameter is used to ensure low speed and low noise.
- Compact design, built-in drain pump

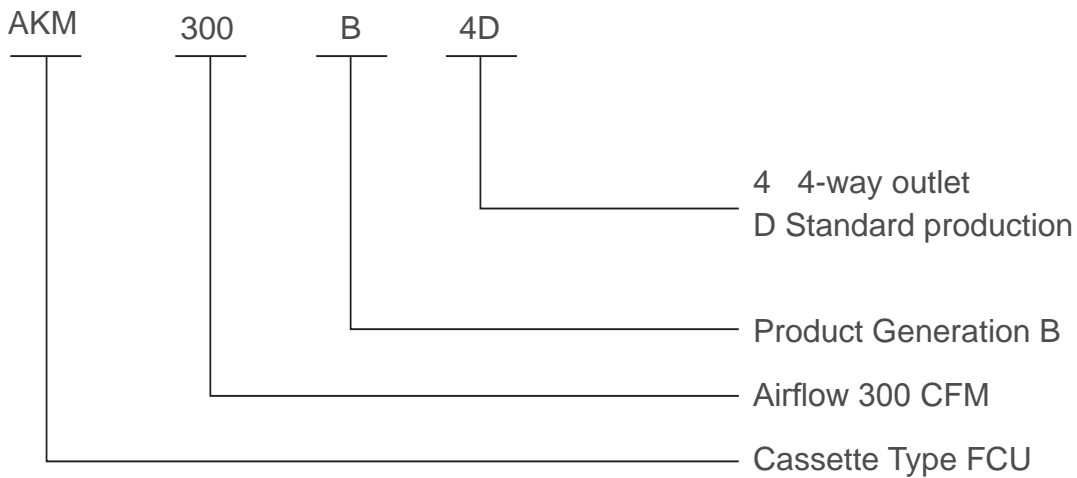
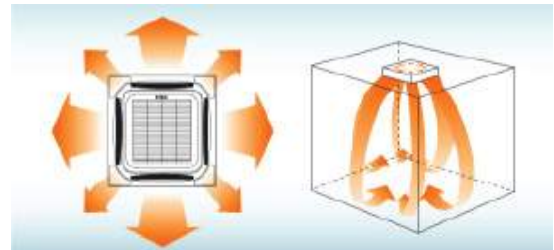

## Cassette Type FCU (Luxury)

Model AKM		300B4D	400B4D	500B4D	600B4D	800B4D	1000B4D	1200B4D
Rated Air Flow (m <sup>3</sup> /h)	High	510	680	850	1020	1360	1700	2040
	Medium	420	560	650	870	1150	1450	1750
	Low	350	460	520	715	950	1190	1430
Cooling Capacity (W)	High	2700	3600	4500	6000	8000	9500	10800
	Medium	2410	3100	3830	5150	6655	8285	9430
	Low	2140	2750	3360	4530	5860	6950	8200
Heating Capacity (W)	High	4050	5400	6750	10000	12500	15500	17000
Power Input (W)	High	50	60	74	85	108	144	183
FCEER	High	49	54	54	60	62	56	51
FCCOP (Water Inlet: 60°C)	High	73	80	82	101	97	92	81
Sound Level (dB(A))	High	39	41	43	40	41	45	48
Fan	Type	Centrifugal fan						
Motor	Type	Single-phase capacitor motor						
Heat Exchanger	Structure Type	Efficient double-flanged aluminum fins and copper tubes, expanded into one						
	Maximum Operating Pressure (MPa)	1.6						
	Water Inlet/Outlet Pipe Diameter	Rc3/4 (Taper Pipe Female Threaded)						
	Water Flow (m <sup>3</sup> /h)	0.48	0.64	0.79	1.1	1.42	1.7	1.85
Water Resistance	kPa	30	30	30	35	40	40	40
Drain Pan	Condensate Water Pipe Diameter	Φ20						
Dimensions (Excluding Decorative Panel)	Length (mm)	570	730	840	840	840	840	840
	Width (mm)	570	730	840	840	840	840	840
	Height (mm)	250	290	230	310	310	310	310
Decorative Panel Dimensions	Length (mm)	650	850	950	950	950	950	950
	Width (mm)	650	850	950	950	950	950	950
Net Weight	kg	23	33	29	34	34	34	35

★ Note:

1. Cooling: supply water and return water temperatures 7/12°C; the dry/wet bulb temperature of air inlet is 27/19.5°C;
2. Heating: supply water is 60°C, water quantity being the same as during cooling; air return conditions: the dry bulb temperature of air inlet is 21°C;
3. The air flow in the table is obtained when the unit is running in dry state and the dry bulb temperature of air inlet is 20°C;
4. The sound pressure level in the table is obtained in a semi-anechoic chamber with noise at 11.5dB(A);
5. AKM\*\*\*C series come with automatic guide plate drive mechanism and pump;
6. The specifications may be changed due to product improvement without a prior notice. The parameters indicated on the unit nameplate should prevail.

## Dimension

### Cassette Type FCU

#### AKM300-500(Dimensions in brackets for AKM500)

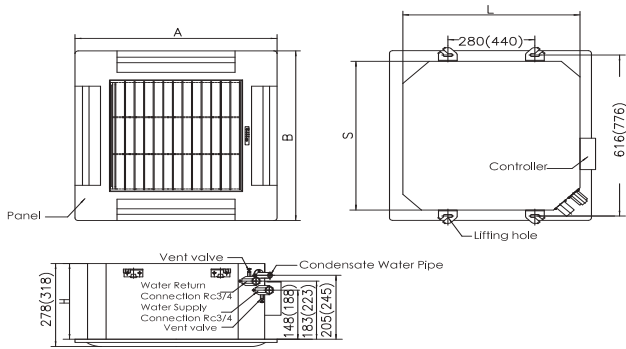

#### AKM600-1200(Dimensions in brackets for AKM600)

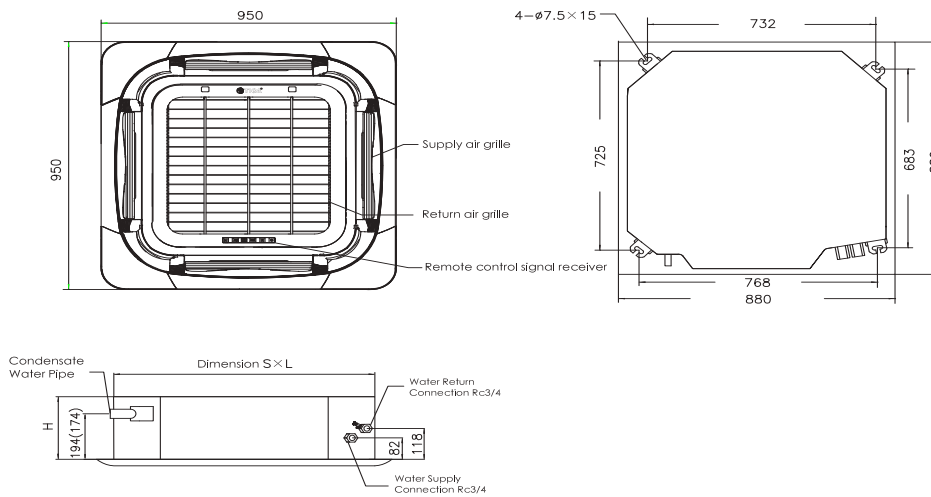

AKM	AKM300	AKM400	AKM500	AKM600	AKM800	AKM 1000	AKM 1200
Panel Dimension (A x B)	650x650	650x650	850x850	950x950	950x950	950x950	950x950
Unit Dimension (S x L x H)	570x570x250	570x570x250	730x730x290	840x840x230	840x840x310	840x840x310	840x840x310
Weight (kg)	23	23	33	29	34	34	35



**Characteristics:**

- Flexible installation, ceiling or floor mounted
- Automatic horizontal and vertical air flow
- One side access hole ,easy for maintenance

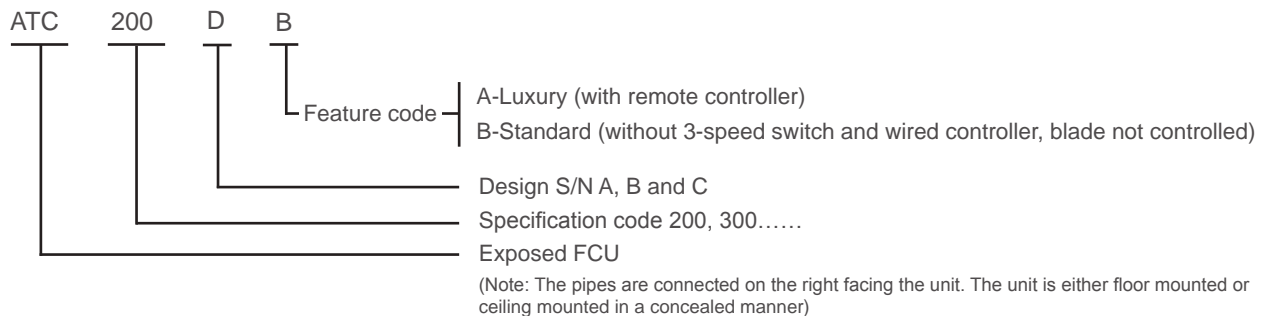

Model ATC		200D	300D	400D	500D	600D	800D	1000D	1200D	1400D
Rated Air Flow (m3/h)	High	350	520	680	850	1030	1360	1700	2040	2380
	Medium	280	440	560	700	870	1255	1450	1830	2100
	Low	230	350	410	570	740	1080	1160	1500	1650
Cooling Capacity (W)	High	1970	2850	3600	4300	5400	6600	8400	9600	10500
	Medium	1675	2400	3060	3655	4590	5610	7140	8160	8900
	Low	1380	1995	2520	3010	3780	4620	5880	6720	7350
Heating Capacity (W)	High	3200	4500	5600	6800	8600	10500	13500	15000	16800
	Medium	2680	3825	4760	5780	7310	8900	11500	12750	14280
	Low	2200	3150	3920	4760	6020	7350	9450	10500	11760
Power Input (W)	High	37	52	62	76	106	134	165	189	228
FCEER	High	51	52	54	52	49	46	48	47	42
FCCOP (Water Inlet: 60°C)	High	83	83	84	82	78	74	77	74	68
Sound Level (dB(A))	High	37	39	41	43	45	46	48	50	52
Fan	Type	Forward-curved multi-blade double inlet centrifugal fan								
Motor	Type	Single-phase capacitor motor								
Heat Exchanger	Structure Type	Efficient double-flanged aluminum fins and copper tubes, expanded into one								
	Maximum Operating Pressure (MPa)	1.6								
	Water Inlet/Outlet Pipe Diameter	Rc3/4 (Taper Pipe Female Threaded)								
	Water Flow (m3/h)	0.34	0.49	0.62	0.74	0.89	1.12	1.44	1.65	1.81
Water Resistance	kPa	12	14	22	26	15	20	20	24	29
Drain Pan	Condensate Water Pipe Diameter	Φ25								
Dimensions	Length (mm)	905			1288			1672		
	Width (mm)	243			243			243		
	Height (mm)	673			673			673		
Net Weight	kg	25			40			45		

★ Note:

1. Cooling: supply water and return water temperatures 7/12°C; the dry/wet bulb temperature of air inlet is 27/19.5°C;
2. Heating: supply water is 60°C, water quantity being the same as during cooling; air return conditions: the dry bulb temperature of air inlet is 21°C;
3. The air flow in the table is obtained when the unit is running in dry state and the dry bulb temperature of air inlet is 20°C;
4. The sound pressure level in the table is obtained in a semi-anechoic chamber with noise at 11.5dB(A);
5. ATC\*\*DB series do not contain a wired controller; ATC\*\*\*DA series contain a remote controller;
6. Thermostat is optional with three speed levels and can be connected to electric valve to realize temperature regulation;
7. The pipes are connected on the right facing the unit;
8. The unit can be in vertical or ceiling installation;
9. The specifications may be changed due to product improvement without a prior notice. The parameters indicated on the unit nameplate should prevail.

# Dimension

## Floor Ceiling Type FCU

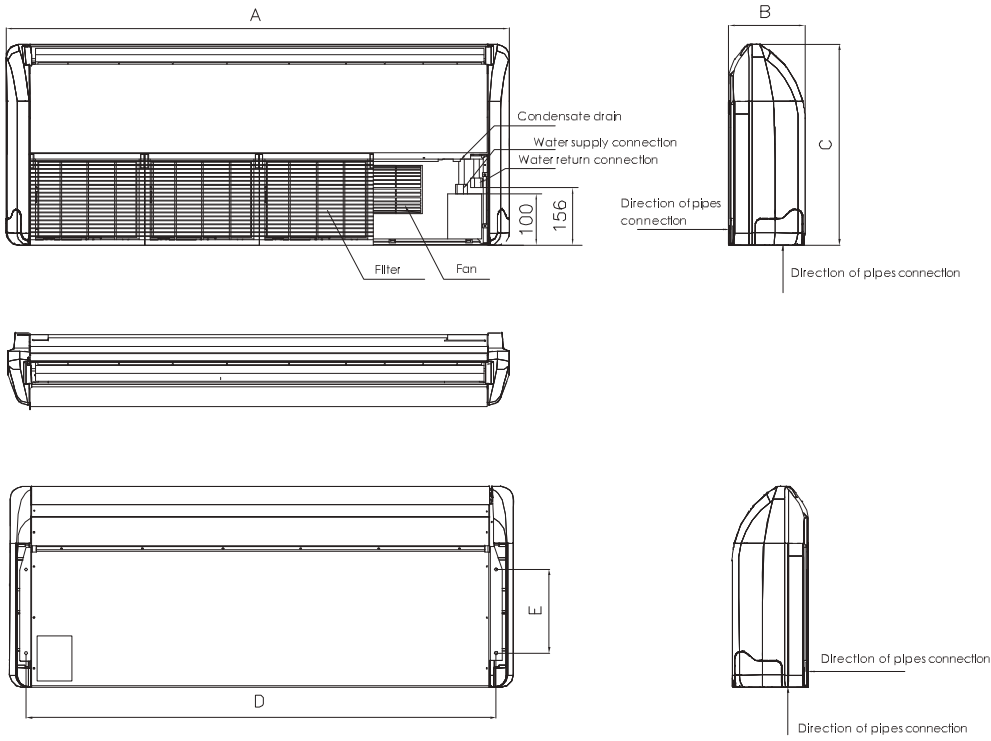

ATC	200	300	400	500	600	800	1000	1200	1400
Dimension	905x243x673				1288x243x637		1672x243x673		
Steeve PiATCh	801x280				1184x280		1569x280		
Fan Quantity	2	2	2	2	3	3	4	4	4

AC Motor Wiring Diagram (applicable to ACR and AFM series)

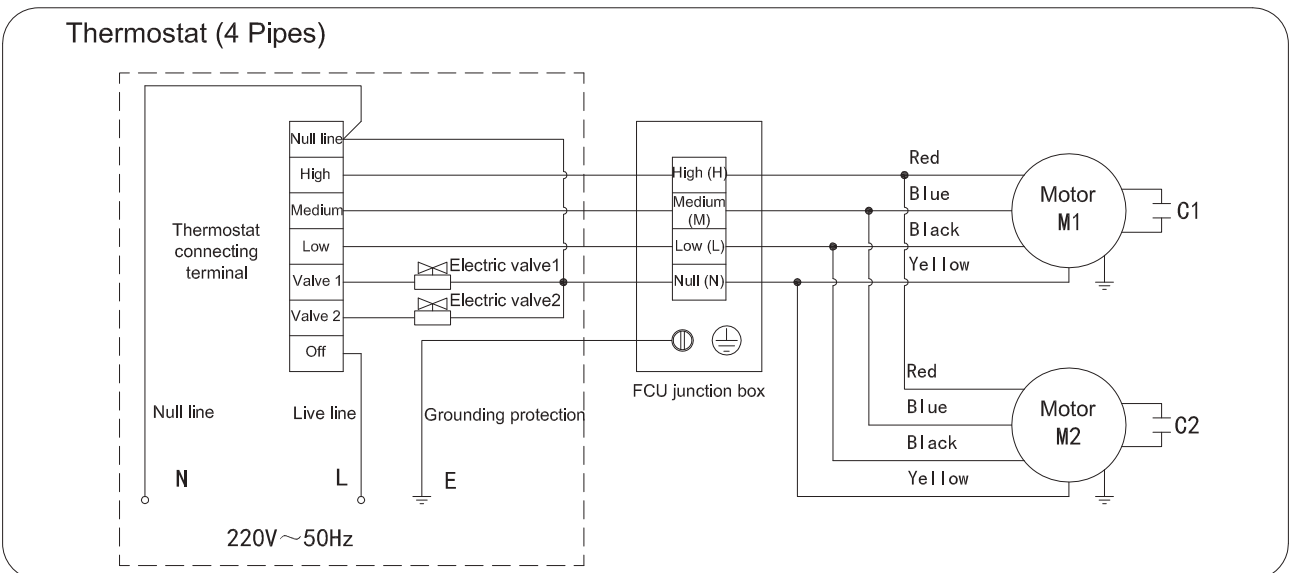
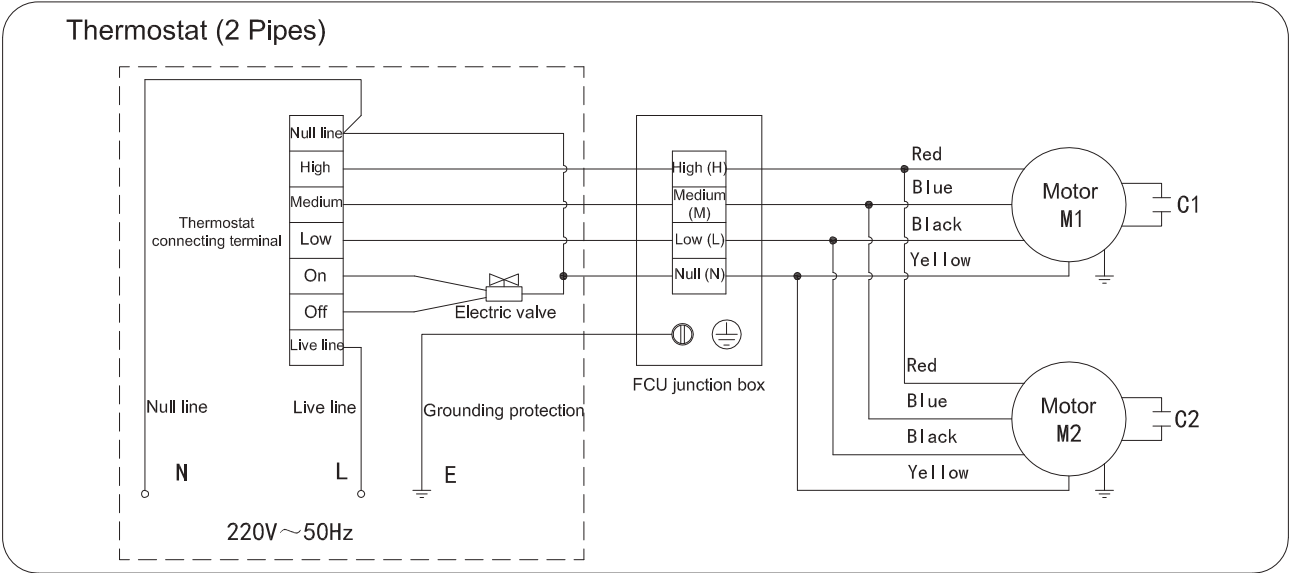



**Brushless DC Motor Wiring Diagram (applicable to ARQ series)**

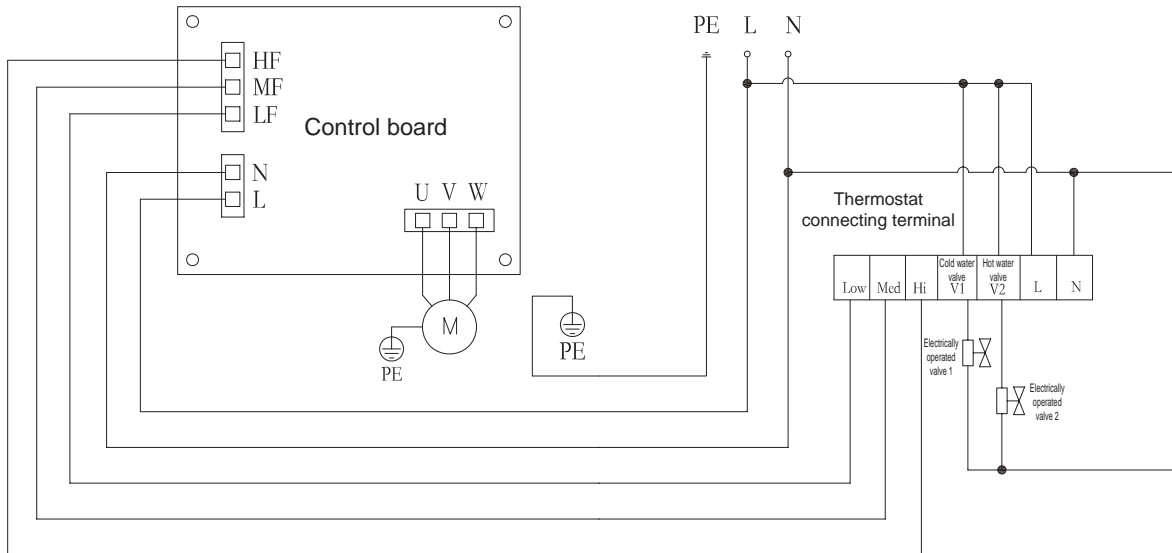

★ Remarks

1. Wiring to be implemented by the customer is indicated in the dashed frame. If the three-speed switch or thermostat is required, please specify when placing an order.
2. The TFM three-speed switch must be able to bear the maximum operating current of the unit or the AC contactor to control the unit.
3. The unit connection must be correct; otherwise, the motor may be burnt out.
4. The voltage, frequency, and phase number of the power supply must be consistent with the unit requirements, and the supply voltage deviation should not exceed 10% of the rated voltage.
5. Disconnect the power supply before maintenance work to prevent electric shock.
6. For the TCR series, only the 800-1400 unit is provided with the motor M2.
7. The electric valve should be matched with the thermostat for use; otherwise, the connection of electric valve may be incorrect. The two-way valve or three-way valve of two-wire system needs to be selected for the 4 pipes FCU.
8. Electric valve 1 is a cold water valve, and electric valve 2 is a hot water valve. No hot water valve is provided for the 2 pipes FCU.

**Model: ATC**

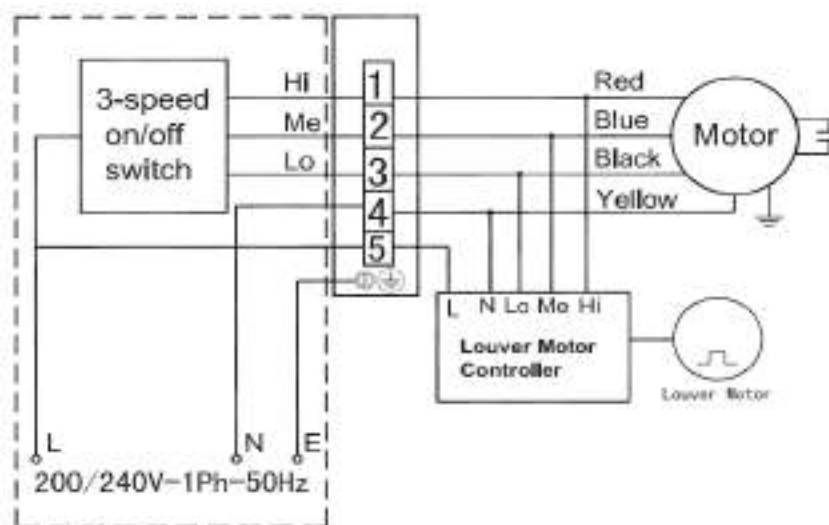

**Model: AKM300B4D-500B4D**

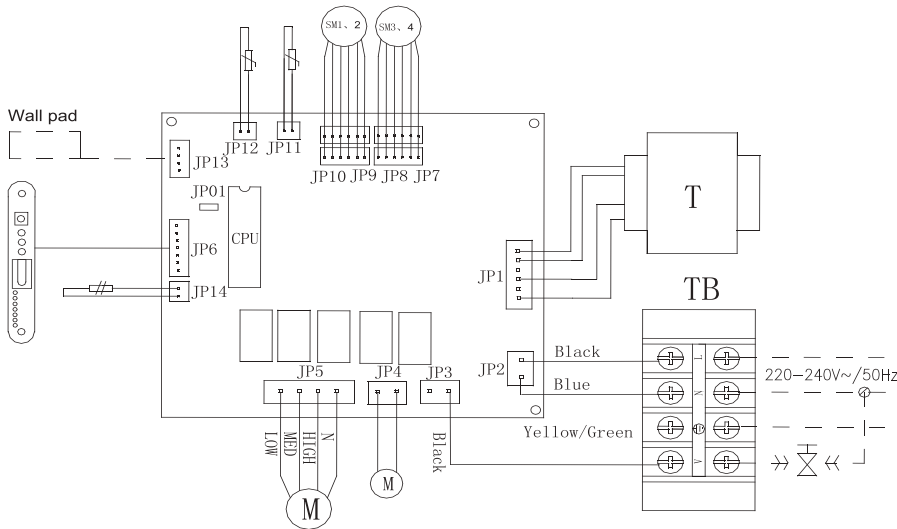

**Legend:**

- JP01---Open is with valve
  - Short is without valve
  - JP1---Transformer
  - JP2---Power supply
  - JP3---2-way valve
  - JP4---Drainage pump
  - JP5---Fan motor
  - JP6---Remote receiver
  - JP7---Stepping motor
  - JP8---Stepping motor
  - JP9---Stepping motor
  - JP10---Stepping motor
  - JP11---Room TEMP. sensor
  - JP12---Indoor coil TEMP. sens
  - JP13---Wall pad
  - JP14---Float switch
- FACTORY WIRING  
 - - - - - FIELD WIRING

**Model: AKM600-1200B4D**

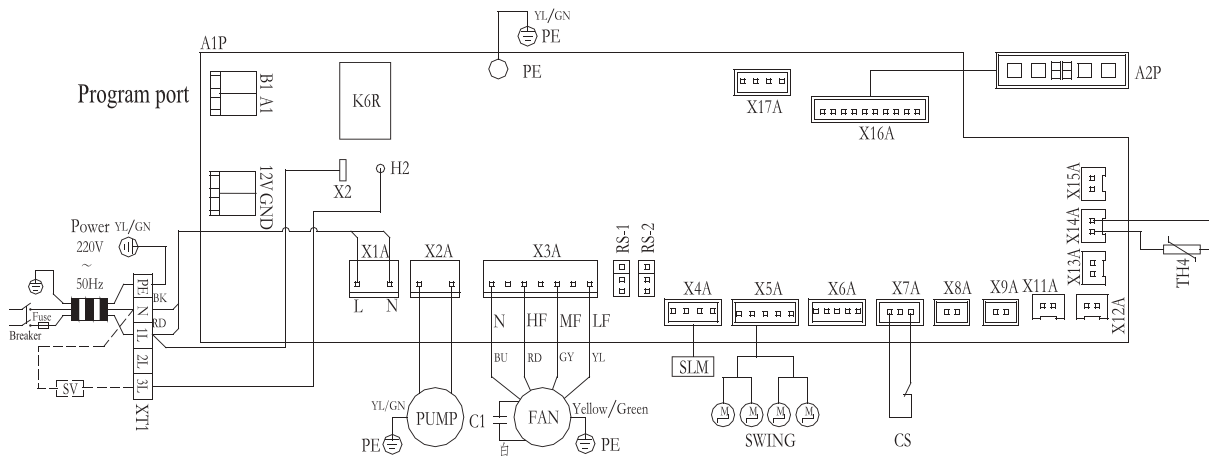

Symbol	A1P	A2P	XT1	PUMP	FAN	SWING	C1	TH4	CS	SLM	SV
Name	Controller	Receiving display circuit board	Terminal block	Pump	Fan motor	Swing motor	Capacitor	Ambient temperture	Water level switch	Remote control	Solenoid valve

**Note:**

- 1 filled wiring, connector
- 2 Wiring only allows copper wire
- 3 Only provides the solenoid valve control port, except solenoid valve

- Handle the unit with care and never handle it by holding its impeller or the volute. Contact the distributor for repair or replacement if it is found, before installation, that the unit is damaged seriously, the volute or the condensate drain pan is deformed or that the motor or the fan loosens.
- When installing the unit, ensure that it is level or the drain side is lower than the other side by 3 ~ 5mm to make the condensate drain pan function smoothly; make sure that the unit only bears its dead load (free from any external load like air ducts and water pipes); reserve sufficient low-maintenance space at the installation position.
- Install a filter screen at the return air inlet to prevent dust blocking the fins of the heat exchanger and ensure its heat-transfer capacity.
- Adopt the top-in and bottom-out pipe connecting system in which the inlet and outlet pipes and recommended to be flexible joints. Do not use excessive torque when connecting pipes, or the heat exchanger may be damaged. Provide thermal insulation measures for the inlet and outlet pipes Seal the threaded connections with tetrafluoroethylene tapes. Keep the drain pipe at a sufficiently low gradient.
- Before initial operation and cold-heat switchover, open the manual air vent valve installed on the outlet pipe of the unit and close it after all air in the coil pipe and the pipeline is vented, or the heat-transfer effect may be not satisfactory Note that the water temperature for cooling in summer and heating in winter shall not be lower than 6°C and greater than 65°C respectively and that clean and softened water is required.
- Provide a single-phase 220V power supply for the unit, with its fluctuation within  $\pm 10\%$ . Carry out wiring against the circuit diagram and do not make any two gears (high, medium and low gears in total) served by the same wire to prevent the motor being burned out. When installing the unit, connect the grounding nut on the housing of the unit with the protective ground system. Never make different models of units share the same three-gear switch, or the motor may also be burned out.
- Clean the heat exchanger period carefully to ensure its satisfactory heat-transfer performance. Clean the filter screen regularly to ensure smooth air return. Never operate the unit for long time unless the filter screen is provided. Fill the coil pipe with water when the unit is shut down for long time, to reduce corrosion of pipes. Take antifreezing measures during installation commissioning and long-time shutdown of the unit in winter, to prevent the coil pipe and water pipe bursting.
- For condensation which may occur on the surface of the unit when chilled water enter the unit but the fan fails to operate, realize interlocking between the electrically operated valve and the temperature detect switch or provide the chilled water bypass; otherwise, manually closing the water inlet valve is the sole solution.
- Make sure that the maintenance of the unit shall be earned out by professional staff who are familiar with the product.

Installation Diagram of Water Pipe

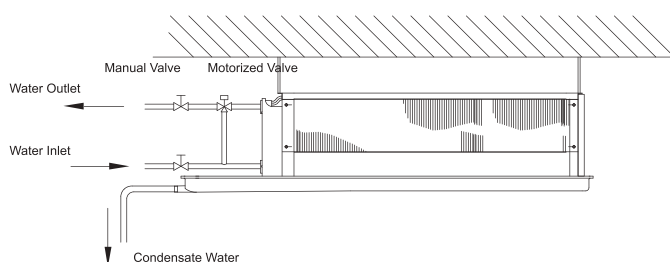

Installation Diagram of Air Duct

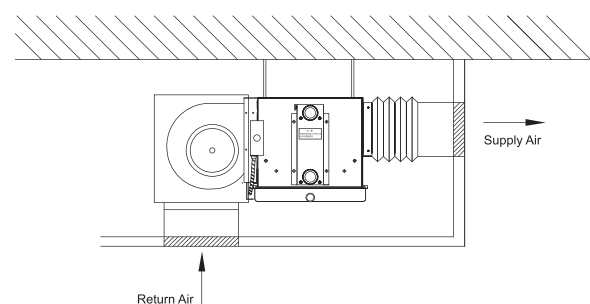

The air conditioning unit is an equipment and users are suggested to record the daily operation data of the equipment and to conduct regular maintenance and service.

1. Daily maintenance durina the equipment use:

Unit maintenance contents	Standard service cycle			Remarks
	Monthly	Quarterly	Half a year	
1. The inspection shall be inspected to confirm whether the power line (from the distribution cabinet to the unit) is loose or damaged.			★	
2. The inspection shall be conducted to confirm whether the condensate discharge is normal		★	●	Is the installation conducted accord ng to the pipe connection diagram? Is it dirty or blocked? Is the drainage smooth? Is there any overflow, etc. due to this?
3. The inspection shall be conducted to confirm whether there is abnormal noise during the operation of the unit.	★		●	For instance, sharp metal friction sound, whistlers, obvious clash and reasonance, significant electromagnetic noise (disgusting) and other abnormal noise.
4. The inspection shall be conducted to confirm whether it is necessary to clean the air side of heat exchanger (surface dust, sundries, etc.)	★	●		Space among fins are full of dust and there are sundries attached on the inlet side of the coil, etc.

2. We recommend the following maintenance and service methixis for the equipment which is not used for a long time
- ◆ In case that the unit does not operate for a long time or does not operate in winter, the power must be turned off and the water shall be discharged from the water system and the steam coil of the unit.
  - ◆ If necessary, the maintenance and service may be conducted according to the pre-use maintenance and service methods of the equipment.

Note:

1. User service: mandatory inspection -- ● recommended inspection -- ★
2. Vulnerable parts required for the service shall be purchased from Airtronics Air-Conditioning Co., Ltd.
3. The service methods apply to the cycle during normal use and the arrangement shall be made based on actual conditions in case of use in bad conditions.

